

Surname	Centre Number	Candidate Number
First name(s)		2



GCE A LEVEL

A420U30-1



THURSDAY, 15 JUNE 2023 – MORNING

PHYSICS – A level component 3

Light, Nuclei and Options

2 hours 15 minutes

ADDITIONAL MATERIALS

In addition to this examination paper, you will require a calculator and a **Data Booklet**.

INSTRUCTIONS TO CANDIDATES

Use black ink or black ball-point pen. Do not use gel pen or correction fluid.

You may use a pencil for graphs and diagrams only.

Write your name, centre number and candidate number in the spaces at the top of this page.

Write your answers in the spaces provided in this booklet. If you run out of space, use the additional page(s) at the back of the booklet, taking care to number the question(s) correctly.

For Examiner's use only			
	Question	Maximum Mark	Mark Awarded
Section A	1.	12	
	2.	15	
	3.	8	
	4.	12	
	5.	6	
	6.	7	
	7.	14	
	8.	7	
	9.	11	
	10.	8	
Section B	Option	20	
	Total	120	

INFORMATION FOR CANDIDATES

This paper is in 2 sections, **A** and **B**.

Section **A**: 100 marks. Answer **all** questions. You are advised to spend about 1 hour 50 minutes on this section.

Section **B**: 20 marks; Options. Answer **one option only**. You are advised to spend about 25 minutes on this section.

The number of marks is given in brackets at the end of each question or part-question.

The assessment of the quality of extended response (QER) will take place in question **5**.



JUN23A420U30101

SECTION AAnswer **all** questions.

1. (a) State what is meant by the wavelength of a **sound wave**. [2]

.....

.....

.....

- (b) (i) Explain clearly why the speed, c , of a wave is given by:

$$c = \frac{\lambda}{T}$$

where λ is the wavelength of the wave and T its period. [2]

.....

.....

.....

- (ii) A student carries out an experiment to measure the speed of sound by using the echo from a distant wall. She measures the distance to the wall as 90.0 m and the time for the echo to arrive back as 0.51 s. Calculate the speed of sound using the student's data. [2]

.....

.....

.....



(iii) Extending her investigation, the student measures the wavelength of low frequency sound waves generated by a loudspeaker. By looking directly at the slow-moving loudspeaker and using a stopwatch, she notices that the loudspeaker takes 7.55 s to complete 20 oscillations. Calculate the wavelength of the sound waves produced. [3]

.....
.....
.....
.....
.....

(iv) The student uses a stroboscope to check the frequency of oscillation of the loudspeaker. She concludes that the frequency of the loudspeaker is 1.3 Hz because the loudspeaker appears stationary when the stroboscope flashes short pulses of light at a frequency of 1.3 Hz. Explain whether this method or that of part (iii) has produced the more accurate value of frequency on this occasion. [3]

.....
.....
.....
.....
.....
.....
.....

A420U301
03

12



2. (a) Complete the diagram to show the diffraction of waves after passing through the slit. [3]

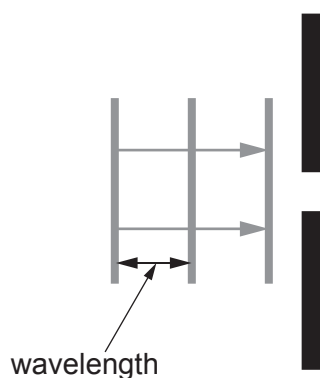

- (b) It is often stated that a diffraction grating should be called an interference grating because the pattern produced is usually called an interference pattern. Explain briefly the importance of **diffraction** in producing this interference pattern. [2]

.....

.....

.....

- (c) John carries out an experiment to measure the number of lines **per cm** of a high-quality diffraction grating. John's set-up is shown below along with the high-quality data that he obtained (he used the wall of the laboratory to maximise the distances he was measuring).

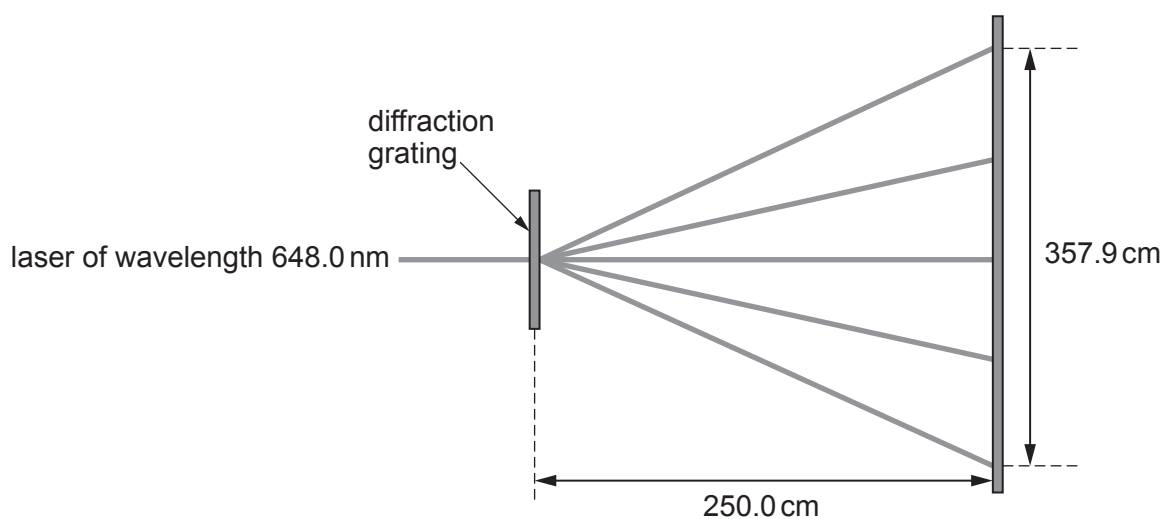

Diagram not drawn to scale



(i) Calculate the number of lines **per cm** for the diffraction grating, quoting your final answer to an appropriate number of significant figures. [5]

.....

.....

.....

.....

.....

.....

.....

.....

.....

.....

.....

(ii) Explain why maximising the distances John was measuring improved the precision of the final answer. [2]

.....

.....

.....

(d) The unknown wavelength of a laser can be measured using a diffraction grating or a double slit. Kevin states that it is better to use a diffraction grating. Evaluate to what extent Kevin is correct. [3]

.....

.....

.....

.....

.....

.....

.....

.....

15

A420U301
05



BLANK PAGE

**PLEASE DO NOT WRITE
ON THIS PAGE**



3. (a) Helen and Valentina carry out a standard experiment to measure the refractive index of a perspex block. They vary the angle of incidence and measure the angle of refraction each time. Their results are tabulated below:

Angle of incidence, $i/^\circ$ ($\pm 0.5^\circ$)	Angle of refraction, $r/^\circ$ ($\pm 0.5^\circ$)	$\sin i$	$\sin r$
0.0	0.0	0.000	0.000
10.0	6.5	0.174	0.113
20.0	13.5	0.342	0.233
30.0	19.5	0.500	0.334
40.0	25.5	0.643	0.431
50.0	31.0	0.766	0.515
60.0	35.5	0.866	0.581
70.0	39.0	0.629
80.0	41.5	0.985	0.663

- (i) Complete the table.

[1]



(ii) Helen produces the following graph:

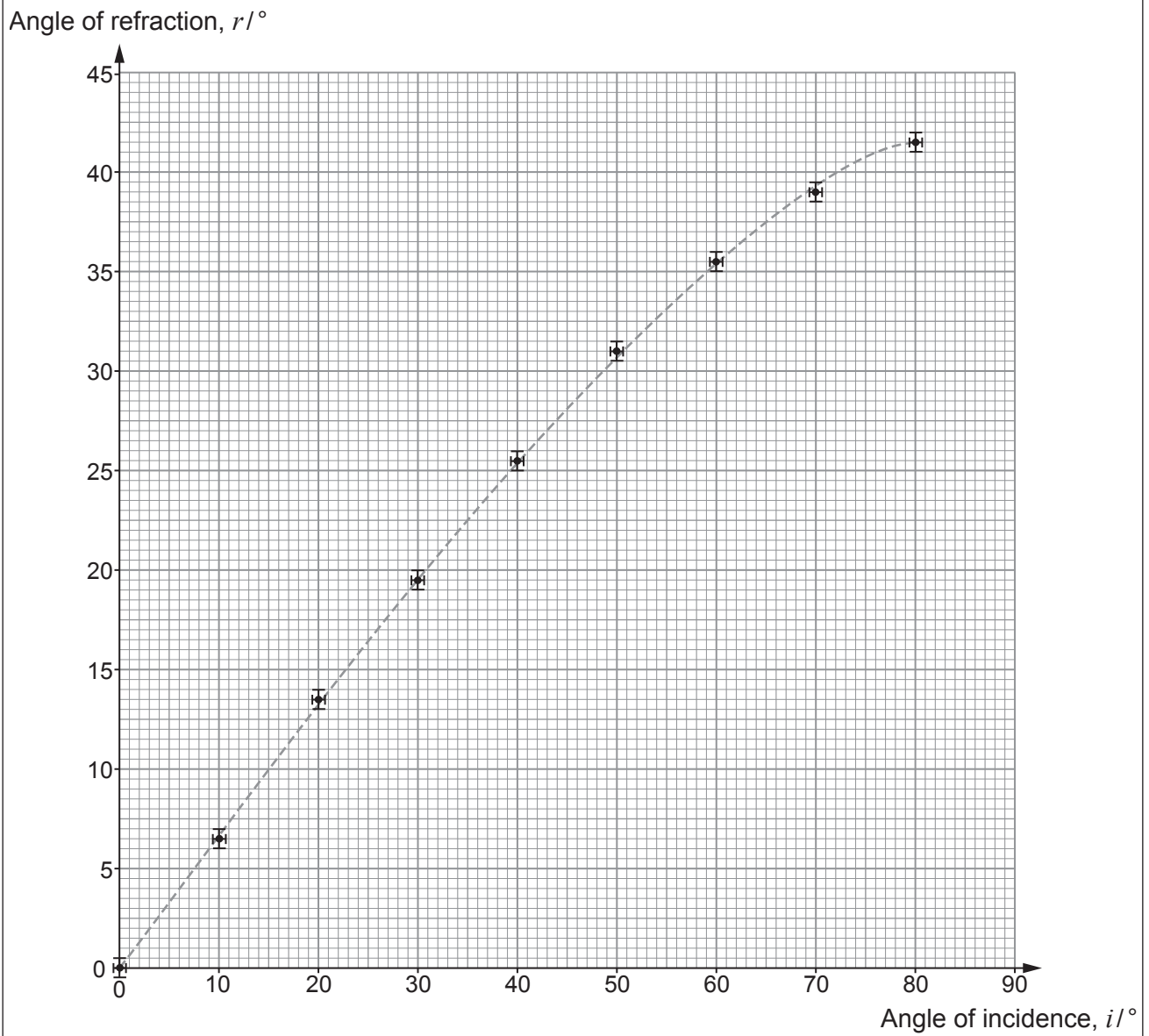

Valentina produces this graph:

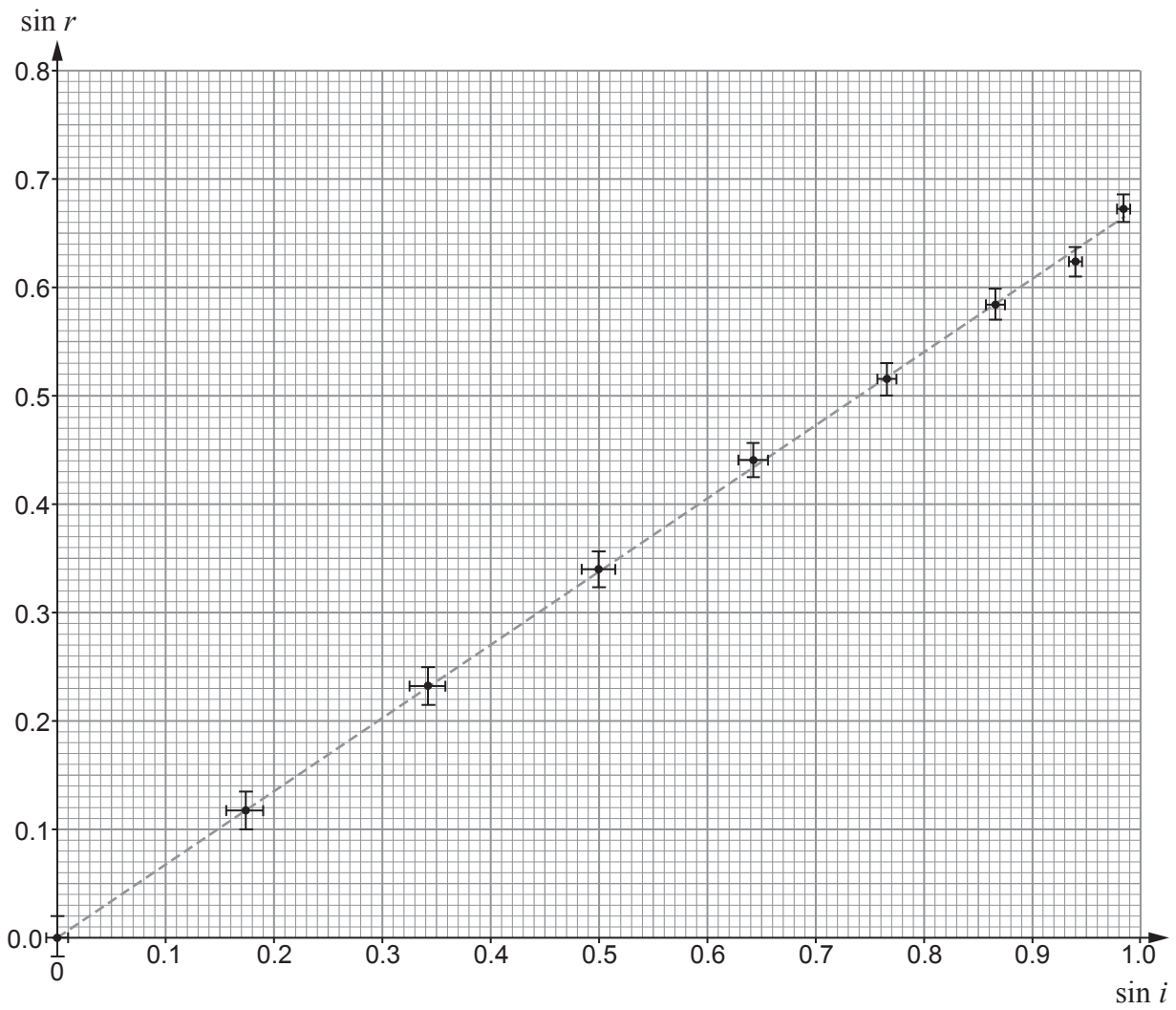

Based on her graph, Helen concludes, “My data show that there is a definite relationship between the angle of incidence and angle of refraction. As the angle of incidence increases, the angle of refraction increases. We know that our results are good because all our points are close to the line of best fit.”

Based on her graph, Valentina concludes, “My data confirms Snell’s law”.

Suggest **two** improvements to **each** of these conclusions that are consistent with the graphs that they have drawn. [4]

.....

.....

.....

.....

.....

.....

.....

.....

.....

.....

(b) Calculate the best value of the refractive index of the perspex block and explain why you chose this method. [3]

.....

.....

.....

.....

.....

8



4. (a) State a typical value for the wavelength of:

(i) microwave radiation [1]

(ii) ultraviolet radiation. [1]

(b) (i) Define the work function for a metal surface. [2]

.....
.....
.....

(ii) Most metals have a work function of a few eV. Using your values from part (a), show that microwaves will not produce the photoelectric effect whereas ultraviolet radiation will. [3]

.....
.....
.....
.....
.....
.....
.....
.....
.....
.....

(iii) Gold has a work function of 5.1 eV. Calculate the maximum speed of electrons emitted from a gold surface when irradiated by photons of wavelength 200 nm. [5]

.....
.....
.....
.....
.....
.....
.....
.....
.....
.....

A420U301
11



6. The metastable energy level of a laser system is (indirectly) pumped at a rate of 5×10^{18} electrons per second.

(a) State what is meant by a metastable energy level. [1]

.....
.....

(b) If the half-life of the metastable energy level is 2.4 ms, explain why the equilibrium number of electrons in the metastable energy level is approximately 1.7×10^{16} (hint: use $A = \lambda N$ or $\frac{\Delta N}{\Delta t} = -\lambda N$). [3]

.....
.....
.....
.....

(c) Hence, explain why it is desirable for the metastable state in a laser system to have a long half-life. [3]

.....
.....
.....
.....

A420U301
13

7



7. (a) Naturally occurring uranium is composed of 99.28% of ${}^{238}_{92}\text{U}$ and 0.72% of ${}^{235}_{92}\text{U}$. The lighter of the 2 isotopes (${}^{235}_{92}\text{U}$) decays via a chain of 7 alpha decays and 4 beta decays to an isotope of lead (Pb).

(i) Calculate the proton number and nucleon number of the lead (Pb) isotope into which the uranium-235 decays. [2]

.....

.....

.....

(ii) When uranium-235 decays to lead, the longest half-life by far is the half-life of uranium-235, which is 704 million years (all other half-lives are tiny and negligible in comparison). A rock is discovered with 80.0% of the original uranium-235 remaining undecayed. Determine the age of the rock. [4]

.....

.....

.....

.....

.....

.....

.....

.....



- (iii) Gareth discovers that uranium-235 and uranium-238 are produced in a supernova in the ratio:

$$\frac{N_{92}^{235}\text{U}}{N_{92}^{238}\text{U}} = 1.5$$

He then concludes that the supernova that produced Earth's uranium occurred around 6400 million years ago. Determine whether Gareth is correct. [5]

Current abundance of uranium-235 = 0.72%

Current abundance of uranium-238 = 99.28%

Half-life of uranium-235 = 704×10^6 year

Half-life of uranium-238 = 4.47×10^9 year

.....

.....

.....

.....

.....

.....

.....

.....

.....

.....



(b) Radon gas is an alpha emitter and is in the decay-chain of uranium. It usually accounts for approximately 50% of background radiation. A builder is told by the local council that she must provide an expensive pump system to eliminate radon gas in new buildings in an area with 10 times the normal background radiation. The builder refuses to do so, stating that it is pointless for buildings that do not have a basement. She also states correctly that 10 times the normal background radiation increases the probability of lung cancer before the age of 75 from 0.4% to only 0.5%.

Discuss briefly whether the builder has used scientific knowledge appropriately in refusing to install the radon pump system. [3]

.....

.....

.....

.....

.....

.....

.....

.....

14



8. In a high energy proton-proton collision, the following reaction is observed:

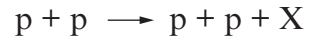

where X is an unknown particle.

- (a) Use conservation of baryon number, charge and lepton number to identify particle X .

[4]

.....

.....

.....

.....

.....

.....

.....

- (b) The unknown particle X is then seen to decay as follows:

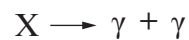

where each gamma photon has an energy of 67.5 MeV.
Calculate the mass of particle X in kg.

[3]

.....

.....

.....

.....

.....



9. Alpha particles, from the source shown, are accelerated in a synchrotron (see diagram). The alpha particles are accelerated by the varying electric field four times during each complete orbit of the synchrotron. The initial speed of the alpha particles is $1.6 \times 10^7 \text{ m s}^{-1}$ along the dotted circle.

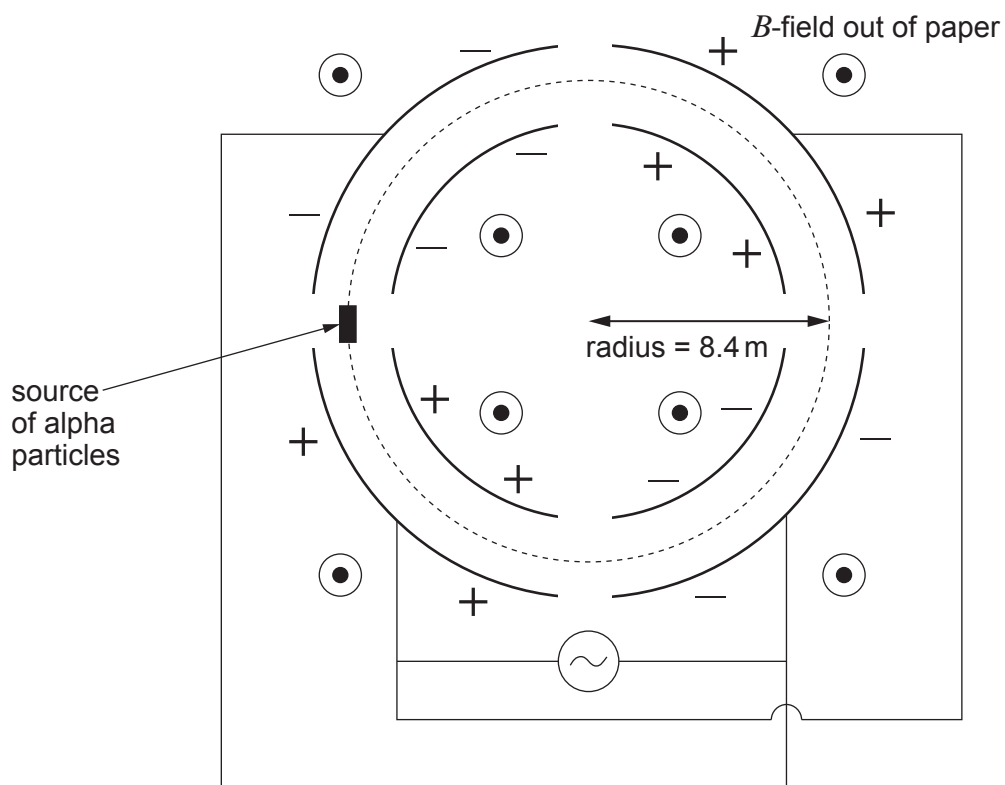

- (a) Place an arrow on the dotted circle to indicate the direction of motion of the alpha particles, and state the name of the rule you used to obtain the direction. [2]

.....

- (b) Calculate the initial magnetic flux density of the synchrotron to ensure that the alpha particles (${}^4_2\text{He}$) follow a circular path. [3]

.....

.....

.....

.....

.....



(c) Calculate the initial frequency of the pd supplied to the synchrotron. [3]

.....
.....
.....
.....
.....

(d) Explain why the kinetic energy (in eV) of the alpha particles in the synchrotron is:

$$\text{kinetic energy (in eV)} = 5.3 \times 10^6 + (8 \times n \times V)$$

where n is the number of orbits completed by the alpha particles and V is the pd of the synchrotron (in volt). [3]

.....
.....
.....
.....
.....
.....
.....

A420U301
19

11



10. (a) A conductor slides horizontally along parallel conductors placed on the ground, as shown. The only magnetic field present is the Earth's magnetic field and the resistances of the conductors are negligible.

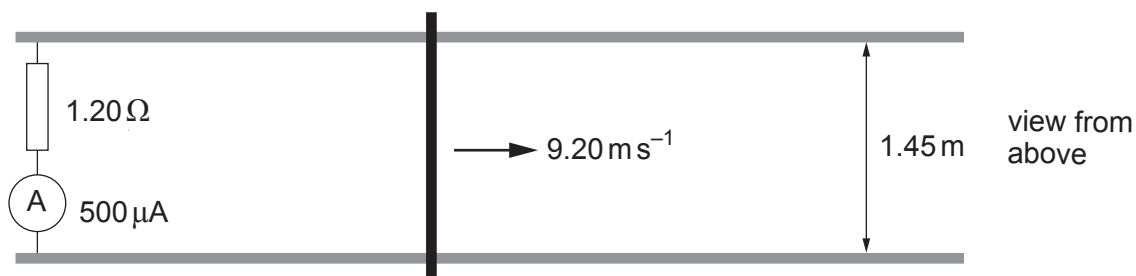

- (i) Explain why the current induced only depends on the **vertical** component of the Earth's field. [1]

.....

.....

- (ii) In the northern hemisphere, the vertical component of the Earth's field is downwards. Explain the direction of the induced current in the circuit. [2]

.....

.....

.....

- (iii) Calculate the vertical component of the Earth's magnetic flux density. [3]

.....

.....

.....

.....

.....



- (b) Rhianna claims that the induced current increases after the sliding conductor reaches point X because of the narrowing of the track. Determine whether or not she is correct. [2]

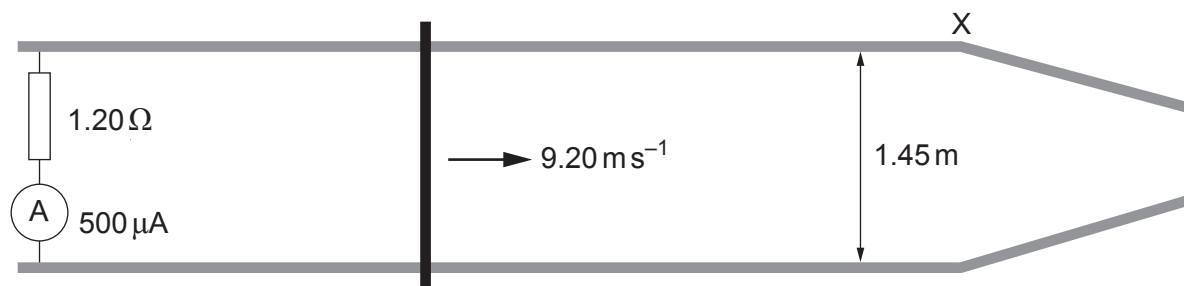

.....

.....

.....



BLANK PAGE

**PLEASE DO NOT WRITE
ON THIS PAGE**



SECTION B: OPTIONAL TOPICSOption A – **Alternating Currents**Option B – **Medical Physics**Option C – **The Physics of Sports**Option D – **Energy and the Environment**

Answer the question on **one topic only**.

Place a tick (✓) in **one** of the boxes above, to show which topic you are answering.

You are advised to spend about 25 minutes on this section.



Option A – Alternating Currents

11. Daniel is investigating a.c. circuits and sets up the circuit shown.

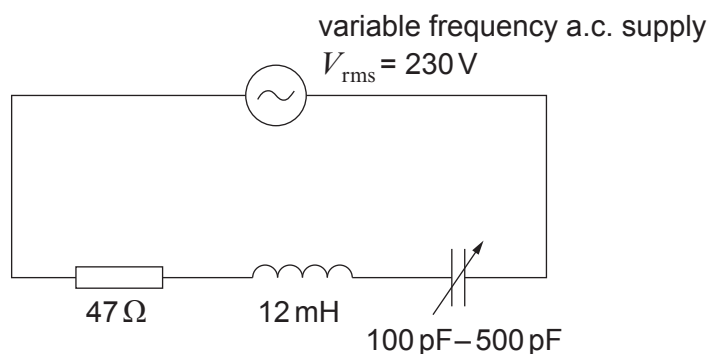

- (a) (i) Show, in clear steps, that the resonance frequency, f_0 , of the circuit is given by: [2]

$$f_0 = \frac{1}{2\pi\sqrt{LC}}$$

.....

.....

.....

- (ii) Calculate the maximum possible resonance frequency for the circuit. [2]

.....

.....

.....

- (iii) Explain why the maximum rms current in this circuit is approximately 5 A. [2]

.....

.....

.....



- (b) Daniel continues his investigation by connecting a different resistor, R , and a fixed capacitor, C , in series with a variable frequency a.c. supply.

variable frequency a.c. supply

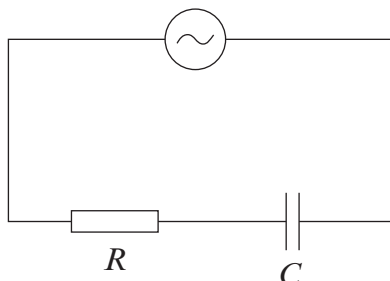

- (i) Use a labelled phasor diagram to explain why the impedance of the circuit, Z , is given by: [4]

$$Z = \sqrt{R^2 + X_C^2}$$

.....

.....

.....

.....

.....

.....

.....

.....

- (ii) Hence show that: [2]

$$Z^2 = \frac{1}{\omega^2 C^2} + R^2$$

.....

.....

.....



- (iii) Using the circuit, Daniel determines Z for a number of different values of ω and plots a graph of Z^2 against $\frac{1}{\omega^2}$.

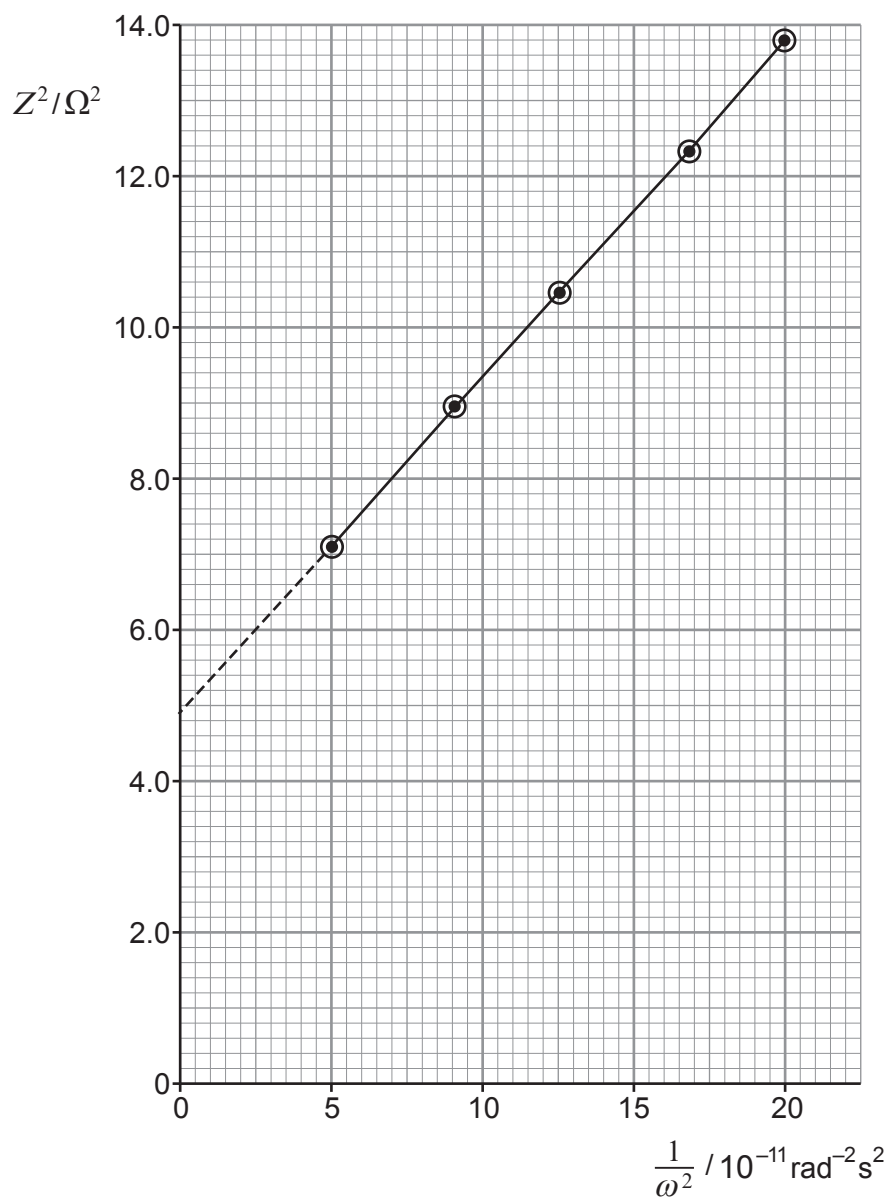

Use the graph to determine the values of the resistor, R , and capacitor, C . [5]

.....

.....

.....

.....

.....

.....

.....

.....

.....

.....

.....

(iv) While carrying out the investigation, Daniel notices that the pd across the resistor, V_R , is small at low frequencies and approaches the supply pd at high frequencies. Explain why this happens. [3]

.....

.....

.....

.....

.....

.....

20



Option B – MEDICAL PHYSICS

Examiner
only

12. (a) (i) An X-ray tube operating with a power of 7.5 kW has a current of 250 mA. Determine its operating voltage. [1]

.....

.....

- (ii) The graph below shows the intensity spectrum for the X-ray tube. Label any features **and** include a numerical value for the minimum wavelength. Space has been left for calculations. [3]

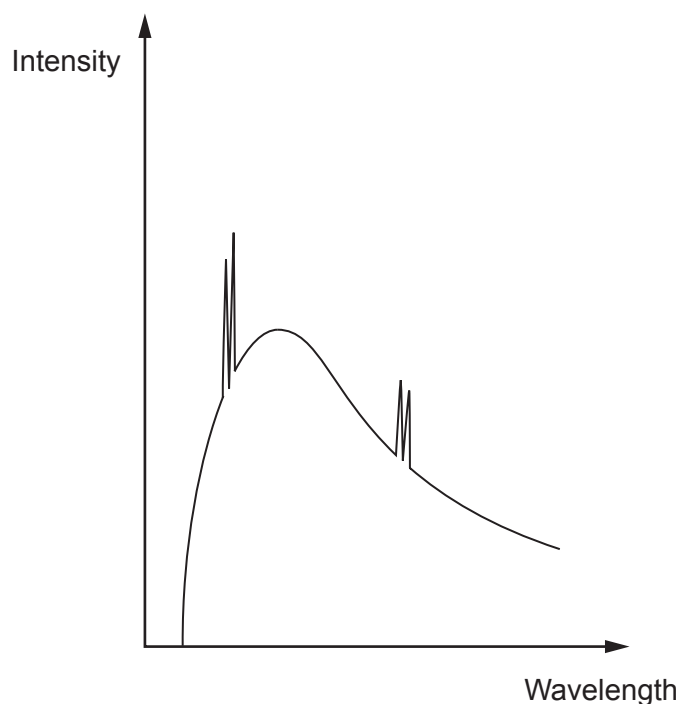

- (iii) **On the diagram above**, draw an intensity spectrum for the same X-ray tube with an operating voltage of 40 kV; again, include a numerical value for the minimum wavelength. [3]

.....

.....

.....

.....

.....



(iv) Discuss if it would be possible to reduce the minimum wavelength to zero. [2]

.....
.....
.....

(b) Doctors are concerned that there is a faulty aortic valve in a patient's heart. They have decided to investigate this further and have the choice of the following:

X-ray MRI ultrasound B-scan radioactive tracers CT scan

Evaluate the suitability of **all five** types of imaging techniques for diagnosing the patient. [5]

.....
.....
.....
.....
.....
.....
.....
.....
.....
.....

(c) Doctors order further tests to examine the rate of blood flow around the body. To determine this, they use ultrasound at a wavelength of 0.45 mm and angle to the blood cells' motion of 15°. Ultrasound travels through blood at a speed of 1400 ms⁻¹. The received wavelength from the red blood cells was found to be shifted by 0.55 μm. Determine the speed of the blood flow. [3]

.....
.....
.....
.....
.....



(d) Explain the operation of PET scans; include which part of the electromagnetic spectrum they detect. [3]

.....

.....

.....

.....

.....

20



BLANK PAGE

**PLEASE DO NOT WRITE
ON THIS PAGE**



Option C – THE PHYSICS OF SPORTS

13. (a) An athlete carries out a balancing exercise using a rope and a pivot while a friend pushes down on the athlete's feet as shown. Calculate the tension, T , in the rope assuming that the athlete is in equilibrium. [3]

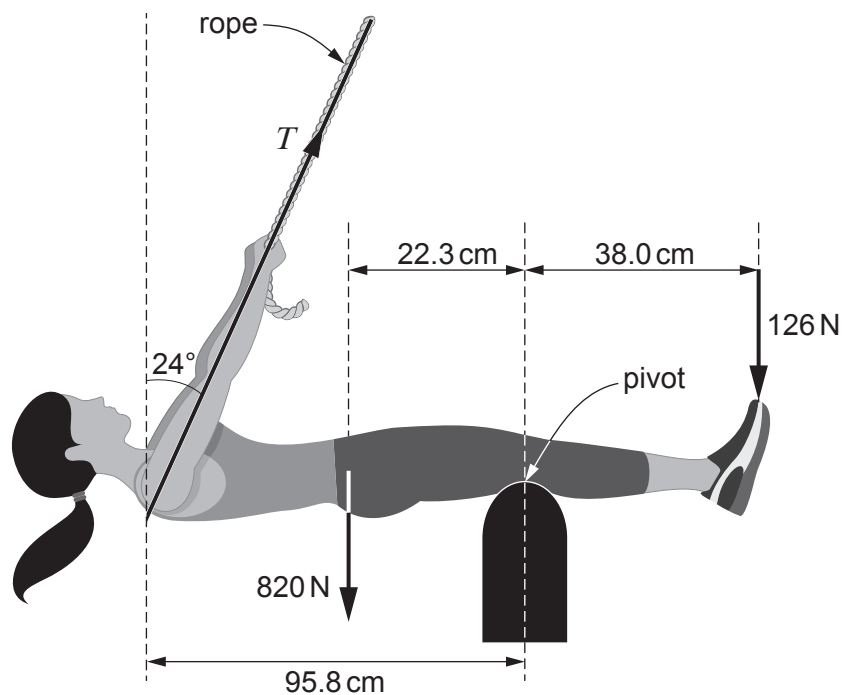

- (b) State what is meant by the moment of inertia of an object. [2]



- (c) A cricket ball is rotating at 300 revolutions per minute. The moment of inertia of the ball is given by the equation $I = \frac{2}{5}mr^2$ where its mass, m , is 0.159 kg and its radius, r , is 3.6 cm.

- (i) Calculate the angular momentum of the ball. [3]

.....

.....

.....

.....

.....

- (ii) The cricket ball is struck by a batsman and the ball acquires a linear speed of 30 m s^{-1} and an angular velocity of 210 rad s^{-1} (about its centre). A sports analyst states that the rotational kinetic energy acquired by the cricket ball is negligible compared with its linear kinetic energy. Show that this statement is correct on this occasion. [3]

.....

.....

.....

.....

.....



- (d) (i) A bowler aims to bowl the ball so that it lands 8.0 m from the batsman. Evaluate whether this can be achieved if the ball is released from a height of 2.0 m at an angle of 8° to the horizontal with a speed of 45 m s^{-1} . Assume that the effects of air resistance are negligible. [5]

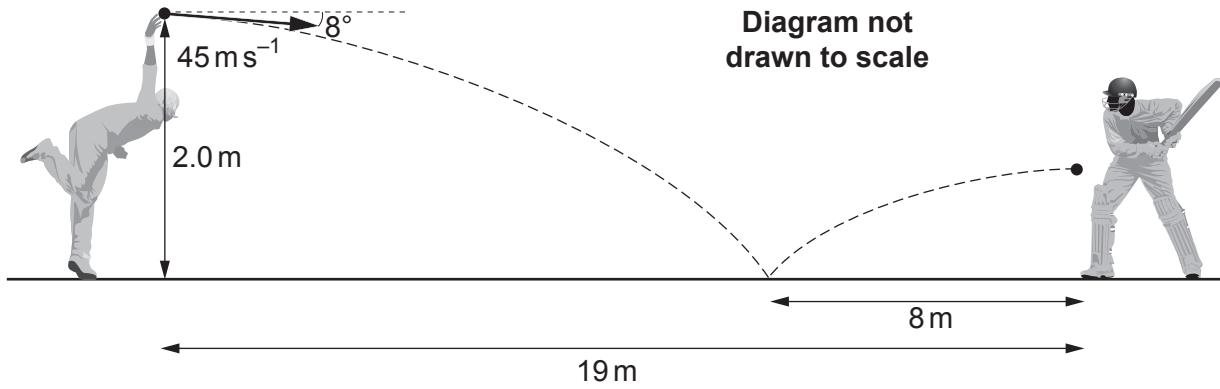

.....

.....

.....

.....

.....

.....

.....

.....

.....

.....



- (ii) The bowler applies topspin to the ball so that it rotates about the horizontal axis as it moves through the air. **Draw arrows on the ball** to show the directions of the air resistance force and the 'lift' force acting on the ball. [2]

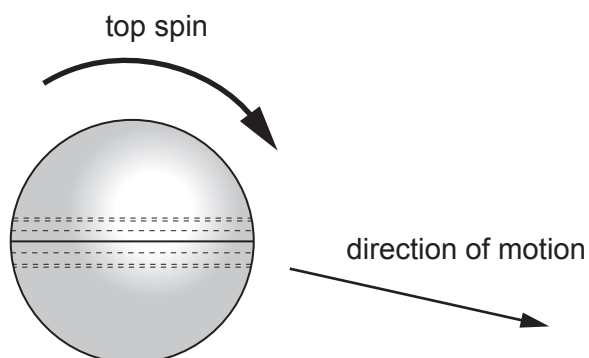

- (iii) Explain briefly what effect these forces have on the position where the ball lands. [2]

.....

.....

.....



BLANK PAGE

**PLEASE DO NOT WRITE
ON THIS PAGE**



Option D – ENERGY AND THE ENVIRONMENT

14. (a) The diagram shows how the mean intensity of solar radiation reaching the Earth system (which includes the Earth and its atmosphere) is distributed.

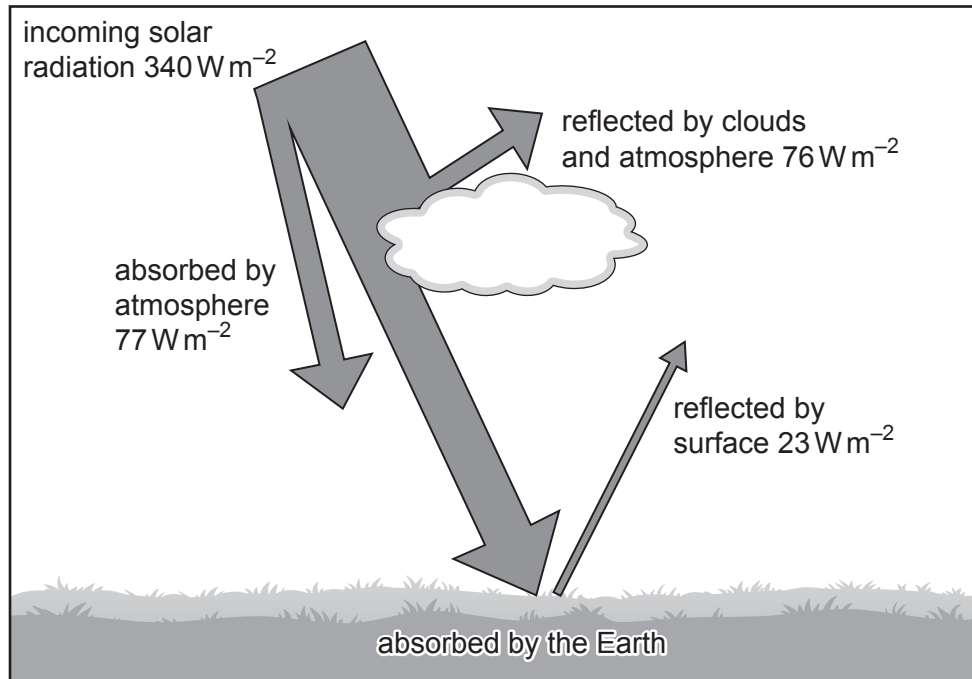

- (i) It is suggested that the fraction of incoming radiation absorbed by the Earth **system** is approximately 0.7. Use the diagram to determine whether this suggestion is correct. [2]

.....

.....

.....

- (ii) State what is meant by the greenhouse effect. [2]

.....

.....

.....



(iii) The Earth system emits 240 W m^{-2} of infra-red radiation into space. This is less than the solar radiation that is absorbed and has caused the temperature of the Earth system to increase. Researchers state this imbalance has approximately doubled since 2005.

I. Explain how human activities are contributing to this change. [3]

.....

.....

.....

.....

.....

II. Describe how an increase in the temperature of the Earth system may lead to further increases in this imbalance. [2]

.....

.....

.....



- (b) A student tests the efficiency of a photovoltaic solar panel using light with an intensity of 350 W m^{-2} . The student positions the light source at an angle of 62° above the horizontal, as shown.

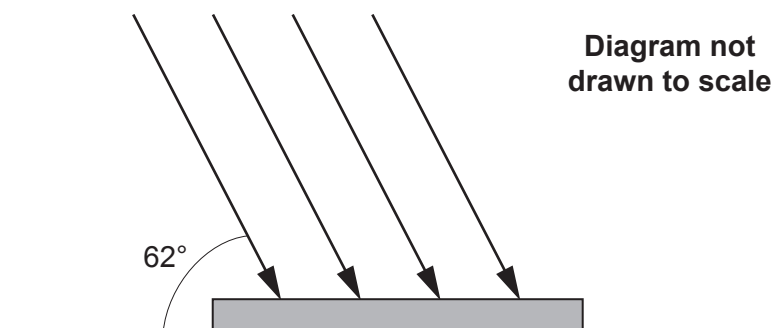

The panel has an area of 1.9 m^2 and produces a power output of 128 W . Determine the efficiency of the panel. [4]

.....

.....

.....

.....

.....

.....

.....

- (c) An uninsulated external wall has a U -value of $1.51 \text{ W m}^{-2} \text{ K}^{-1}$.

(i) Explain what this statement means. [2]

.....

.....

.....



- (ii) Charlie replaces part of his uninsulated external wall with patio doors and adds insulation to the remainder of the wall.

BEFORE

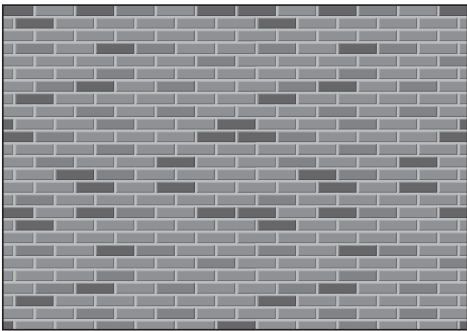

Uninsulated external wall

AFTER

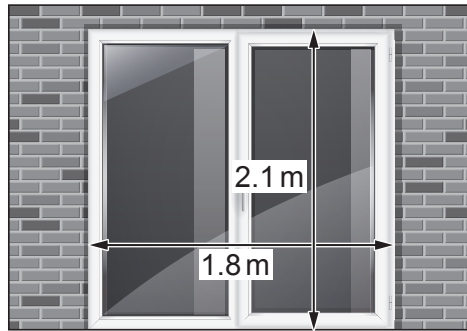

Insulated external wall with patio doors

Diagrams not drawn to scale

The graph below shows how the rate of energy transfer from the original uninsulated external wall varies with external temperature on a windless day.

Rate of energy transfer/W

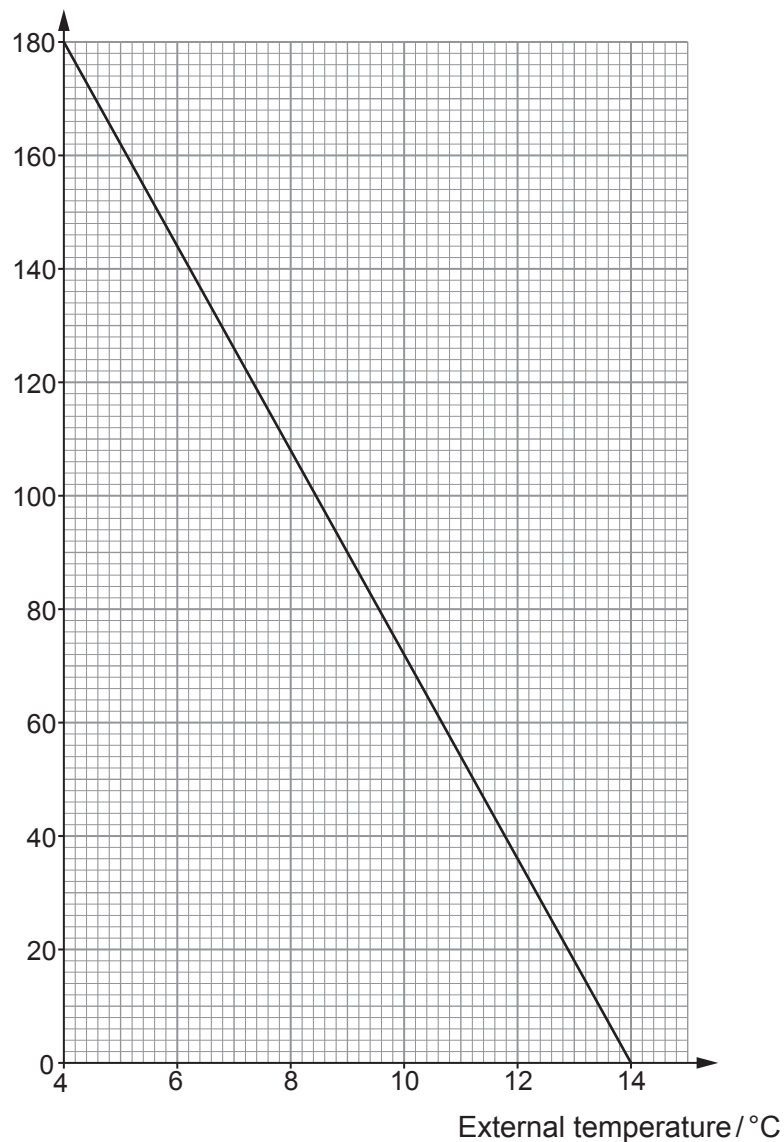

- I. Use the graph to show that the area of the original wall is approximately 12 m^2 ($U\text{-value} = 1.51\text{ W m}^{-2}\text{ K}^{-1}$). [2]

.....

.....

.....

- II. After the renovation, under the same windless conditions, the heat transfer from the insulated external wall with patio doors is found to be 65 W when the temperature difference between the inside and outside is $10\text{ }^\circ\text{C}$. The $U\text{-value}$ of the patio doors is $1.34\text{ W m}^{-2}\text{ K}^{-1}$. Charlie calculates the $U\text{-value}$ of the insulated wall to be less than $0.2\text{ W m}^{-2}\text{ K}^{-1}$. Determine whether Charlie is correct. [3]

.....

.....

.....

.....

.....

20

END OF PAPER



BLANK PAGE

**PLEASE DO NOT WRITE
ON THIS PAGE**



BLANK PAGE

**PLEASE DO NOT WRITE
ON THIS PAGE**

