

Thursday 25 May 2023 – Morning

GCSE (9–1) Combined Science A (Physics) (Gateway Science)

J250/05 Paper 5 (Foundation Tier)

Time allowed: 1 hour 10 minutes



You must have:

- a ruler (cm/mm)
- the Equation Sheet for GCSE (9–1) Combined Science A (Physics) (inside this document)

You can use:

- a scientific or graphical calculator
- an HB pencil



Please write clearly in black ink. **Do not write in the barcodes.**

Centre number

--	--	--	--	--

Candidate number

--	--	--	--

First name(s)

Last name

INSTRUCTIONS

- Use black ink. You can use an HB pencil, but only for graphs and diagrams.
- Write your answer to each question in the space provided. If you need extra space use the lined pages at the end of this booklet. The question numbers must be clearly shown.
- Answer **all** the questions.
- Where appropriate, your answer should be supported with working. Marks might be given for using a correct method, even if your answer is wrong.

INFORMATION

- The total mark for this paper is **60**.
- The marks for each question are shown in brackets [].
- Quality of extended response will be assessed in questions marked with an asterisk (*).
- This document has **24** pages.

ADVICE

- Read each question carefully before you start your answer.

2
Section A

You should spend a **maximum of 20 minutes** on this section.

Write your answer to each question in the box provided.

- 1** A spaceship travels from planet **P** to planet **Q**.
The diagram shows the size of the forces acting on the spaceship.

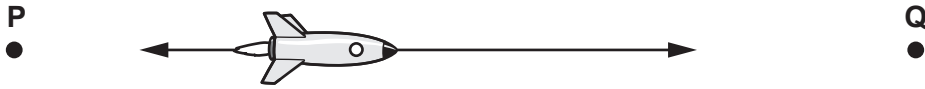

Which sentence describes the motion of the spaceship?

- A** It is accelerating.
- B** It is decelerating.
- C** It is staying at a constant speed.
- D** Its speed is decreasing then increasing.

Your answer

[1]

- 2** Velocity is a vector.

Which row is correct for velocity?

	Has size?	Has direction?
A	no	no
B	no	yes
C	yes	no
D	yes	yes

Your answer

[1]

3 Which voltmeter shows a reading of 0.5V?

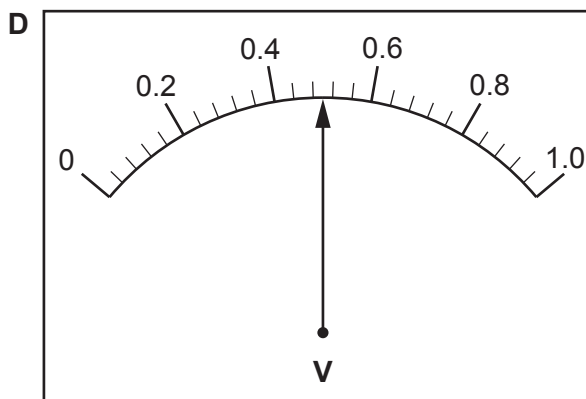
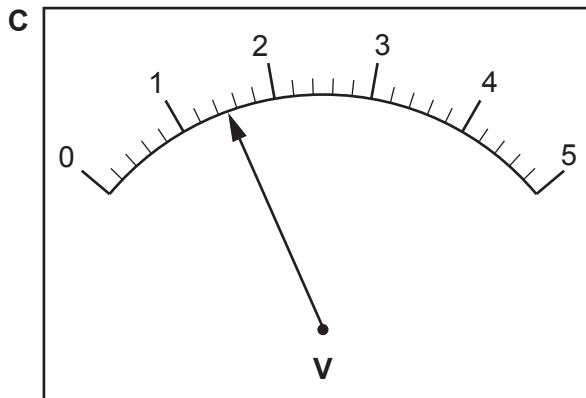
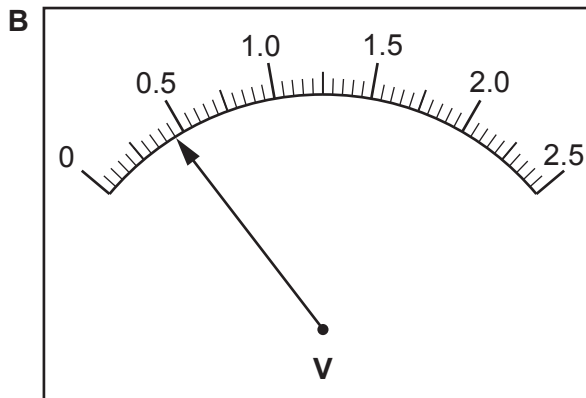
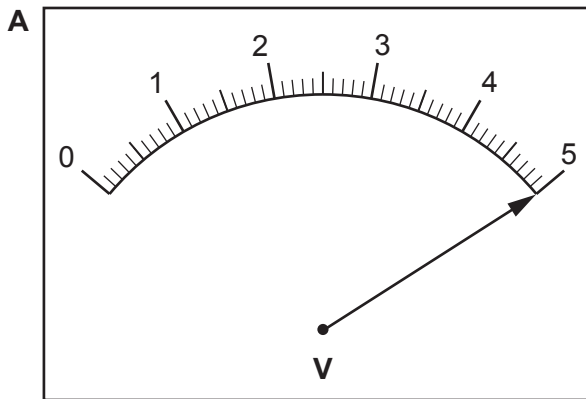

Your answer

[1]

4 The diagram shows the magnetic field around a bar magnet.

At which point is the magnetic field the **weakest**?

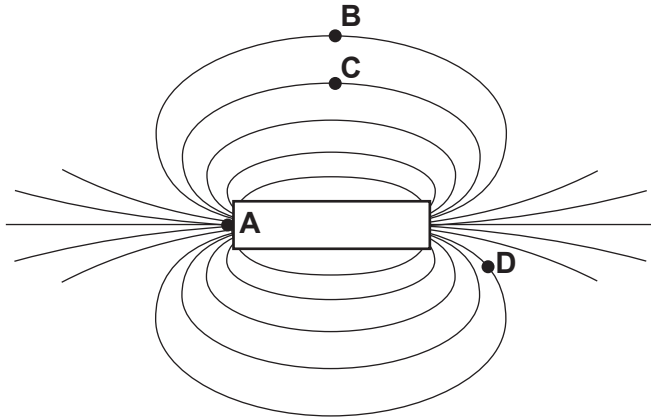

Your answer

[1]

5 Which substance listed in the table has the highest **density**?

Substance	Mass (kg)	Volume (cm ³)
A	1.0	1.5
B	1.0	3.0
C	1.0	4.5
D	1.0	6.0

Your answer

[1]

6 How much of the total mass of a hydrogen atom is made up by the nucleus?

- A None of the mass
- B Half of the mass
- C Almost all of the mass
- D All of the mass

Your answer

[1]

- 7 The mass of an astronaut is 80 kg.

Calculate the weight of the astronaut on the Moon.

Use the equation: gravitational force = mass \times gravitational field strength

The gravitational field strength on the Moon is 1.6 N/kg.

- A 50 N
B 128 N
C 800 N
D 1280 N

Your answer

[1]

- 8 The table shows the results from measuring the extension of a spring for different forces.

Force (N)	Extension of a spring (m)
0.0	0.00
0.9	0.05
1.8	0.10
2.7	0.15
3.6	0.20

Calculate the spring constant of the spring.

Use the equation: force exerted by a spring = extension \times spring constant

- A 0.045 N/m
B 0.060 N/m
C 0.72 N/m
D 18 N/m

Your answer

[1]

9 Which new feature of the atomic model did Niels Bohr suggest?

- A Electrons are in stable shells.
- B Electrons orbit a nucleus.
- C The atom has a nucleus.
- D The nucleus is positive.

Your answer

[1]

10 Two rooms have the same fixed volume. They contain identical gases at the same pressure.

Room **H** is at a higher temperature than room **L**.

Which statement is correct?

- A The particles are moving at the same speed in both rooms.
- B The particles are moving faster in room **H**.
- C The particles are moving faster in room **L**.
- D The particles are not moving in either room.

Your answer

[1]

7
BLANK PAGE

PLEASE DO NOT WRITE ON THIS PAGE

8
Section B

11 (a) Draw lines to connect each **circuit component** with its correct **symbol**.

Circuit component

Symbol

Diode



LDR



Thermistor

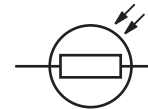

[2]

(b) Complete the sentences to describe electrical circuits.

Use words from the list.

increases decreases stays the same

A circuit contains one resistor. An identical resistor is added **in series** with the first. The resistance of the circuit

A circuit contains one resistor. An identical resistor is added **in parallel** with the first. The resistance of the circuit

If the temperature of a thermistor increases, its resistance

[2]

(c) Fig. 11.1 shows circuit symbols for an ammeter, voltmeter and resistor.

Fig. 11.1



A student measures the current in a resistor and the potential difference across the resistor.

Use the symbols in Fig. 11.1 to complete a circuit diagram for the experiment.

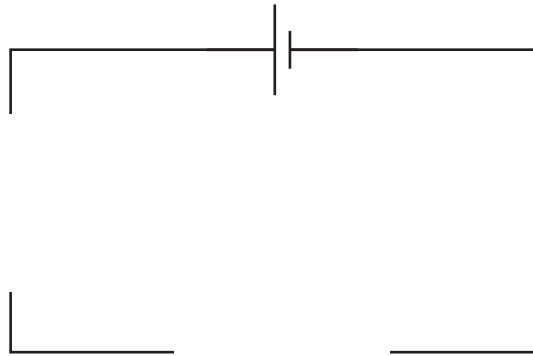

[2]

(d) The potential difference across a 3Ω resistor is 4.5V .

Calculate the current in the resistor.

Use the Equation Sheet.

Current = A [3]

- (e) (i) A teacher connects the circuit in **Fig. 11.2**.

Fig. 11.2

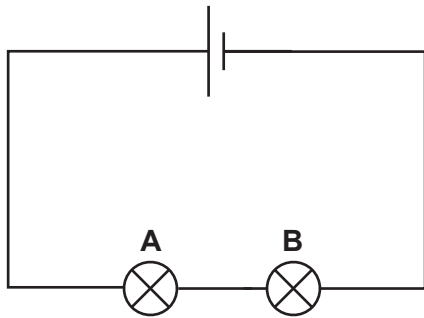

Both lamps are lit. The teacher then removes lamp **A** from its holder but leaves the rest of the circuit unchanged.

Describe what happens. Give a reason for your answer.

What happens

.....

Reason

.....

[2]

- (ii) The teacher connects the circuit in **Fig. 11.3**.

Fig. 11.3

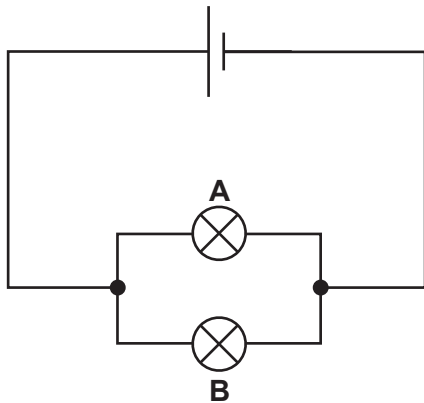

Both lamps are lit. The teacher then removes lamp **A**.

Describe what happens. Give a reason for your answer.

What happens

.....

Reason

.....

[2]

- (f) The graph shows how the current in a resistor changes when the potential difference across the resistor changes.

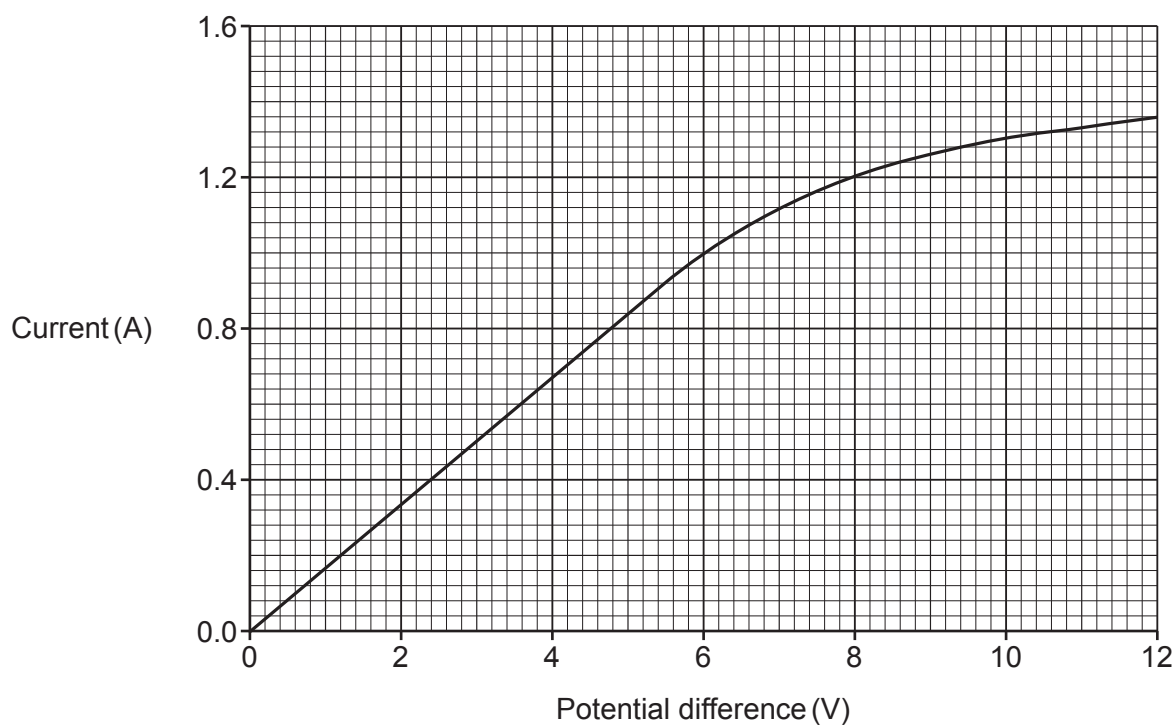

Which **two** statements about the graph are correct?

Tick (✓) **two** boxes.

The graph is linear when the current is more than 1.0A.

The graph is linear when the potential difference is less than 4 V.

The graph is non-linear for all values of current.

The ratio of potential difference : current is unchanged from 0V to 5V.

When potential difference increases, resistance decreases.

[2]

12 A student does an experiment to measure the power rating of a Bunsen burner.

The diagram shows their experiment.

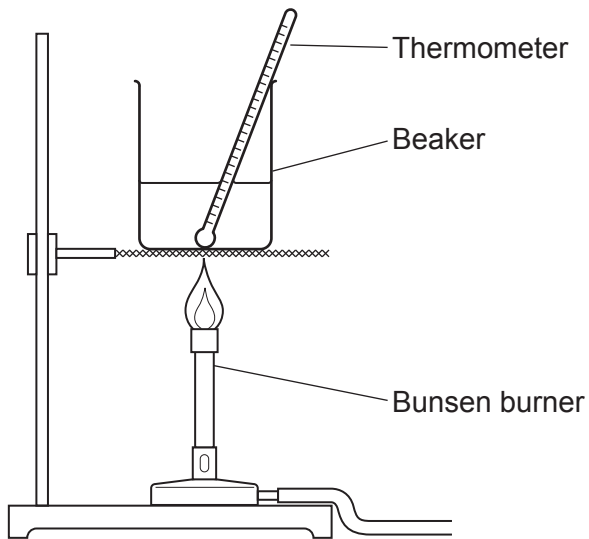

This is the method they follow:

- Pour 0.2 kg of water into a beaker.
- Increase the temperature of the water using the Bunsen burner.
- Measure the time taken for the temperature of the water to increase by 50 °C.

(a) Suggest a way to measure the time taken.

..... [1]

(b) The mass of the water is 0.2 kg. The temperature change is 50 °C.

The specific heat capacity of water is 4200 J/kg °C.

Calculate the thermal energy transferred to the water.

Use the Equation Sheet.

Thermal energy transferred = J [2]

- (c) The student repeats the experiment.
They say that the energy transferred by the Bunsen burner is 40 000 J after 200 s.

Calculate the power of the Bunsen burner.

Use the equation: $\text{power} = \frac{\text{energy transferred}}{\text{time}}$

Power = W [2]

- (d) Another student repeats the experiment for two Bunsen burners **A** and **B**.

The graph shows the time taken for the temperature of 0.2 kg of water to increase by 50 °C.

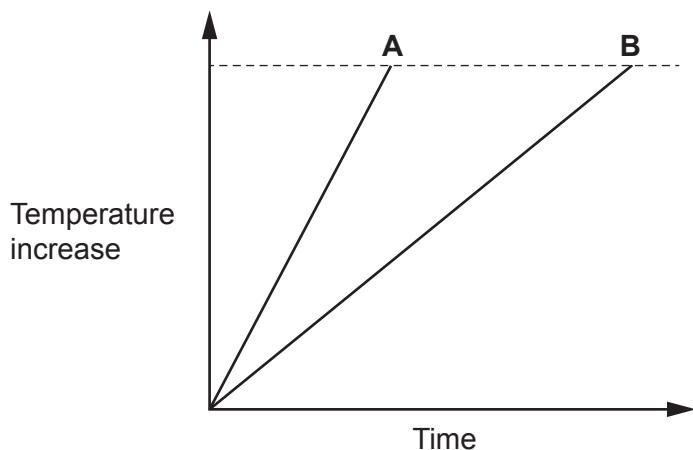

- (i) The student says, 'Bunsen burner **A** has the highest power.'

Explain how the graph shows this.

.....
 [1]

- (ii) The manufacturer says, 'The line on the graph for Bunsen burner **B** is **not** accurate. The power of the Bunsen burners should be the same.'

Both Bunsen burners are working correctly.

What did the student do wrong when testing Bunsen burner **B**?

Tick (✓) **one** box.

- They used too much water.
- They wrapped insulation around the beaker.
- They placed a lid on the beaker.
- They started recording the time too late.

[1]

13 A boy and a girl walk from their house to a shop. They walk there in different ways.

The distance–time graph shows their motion.

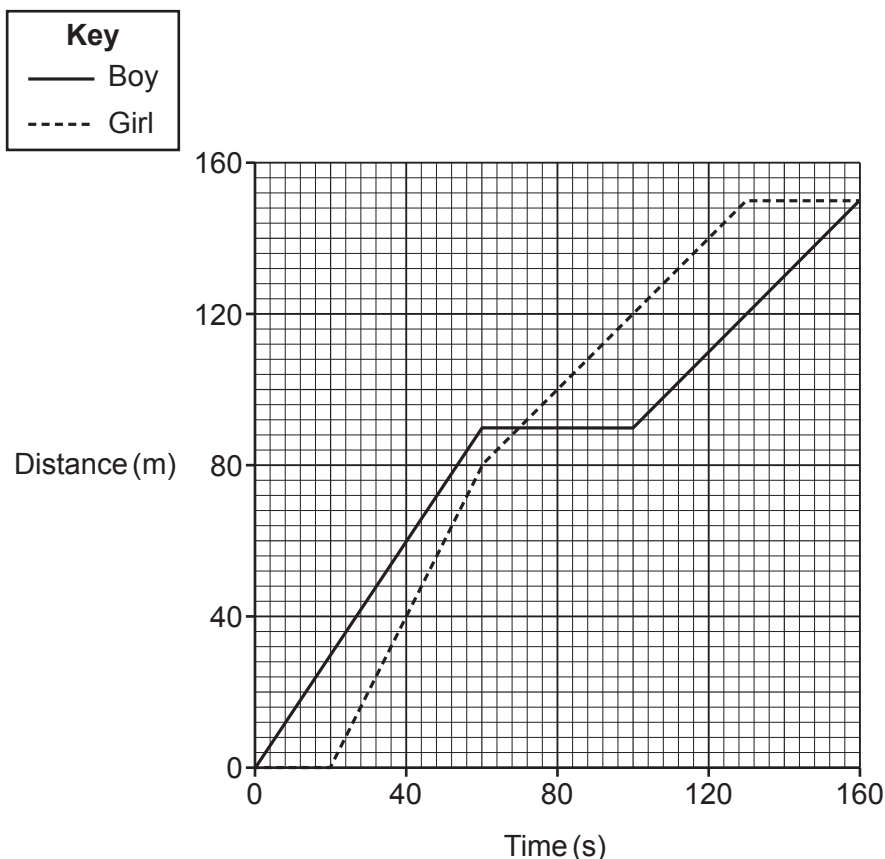

(a) How long does the boy stop for during the walk?

Time stopped = s [1]

(b) The boy and girl are at the same distance from the house when they are at the shop.

At what **other** time are the boy and girl at the same distance from the house?

Other time = s [1]

(c) Calculate the boy's average speed for the whole journey.

Use the Equation Sheet.

Give your answer to **2** significant figures.

Average speed = m/s [4]

(d) The girl walks back to the house. She accelerates for part of the journey.

(i) Which distance–time graph describes her motion for this part of her journey?

Tick (✓) **one** box.

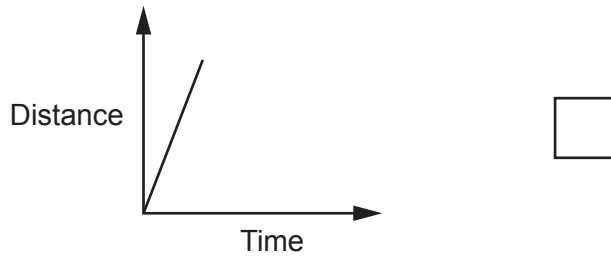

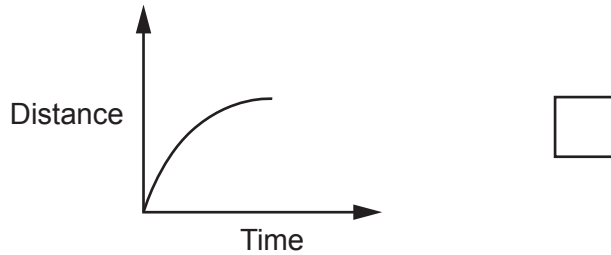

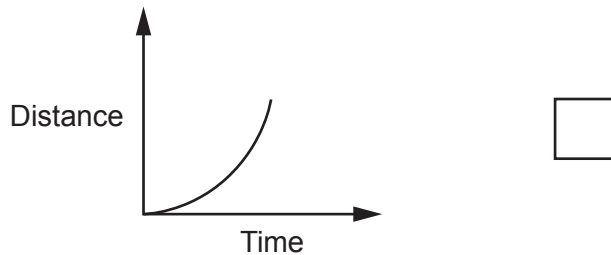

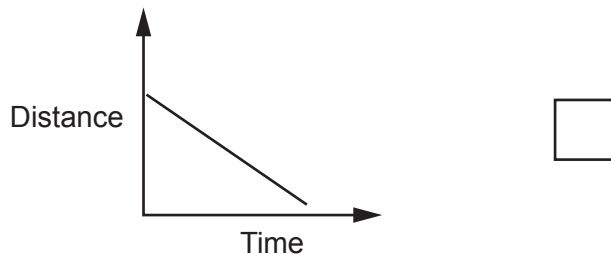

[1]

(ii) The girl's change in velocity is 1.2m/s. The time taken is 3 seconds.

Calculate the girl's acceleration.

Use the equation: acceleration = $\frac{\text{change in velocity}}{\text{time}}$

Acceleration = m/s² [2]

- (iii) The free body force diagram shows how the girl accelerates as she walks along the ground.

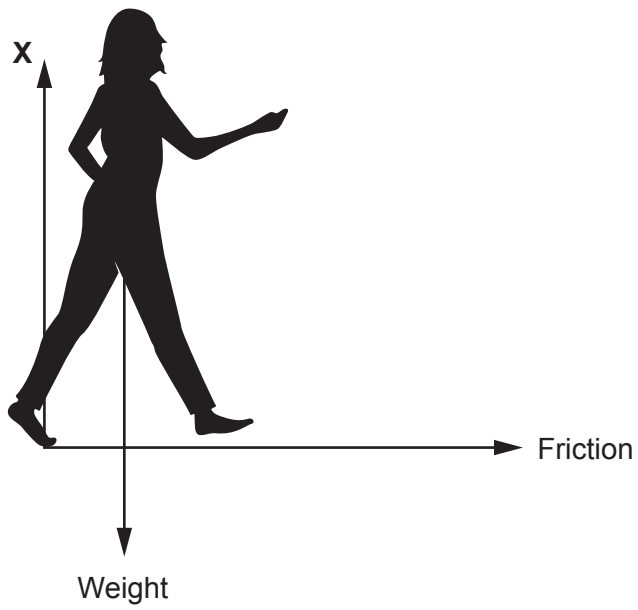

What is the name of force **X**?

Tick (✓) **one** box.

Air resistance

Gravity

Normal contact force

Upthrust

[1]

19
BLANK PAGE

PLEASE DO NOT WRITE ON THIS PAGE

15 Fig. 15.1 shows a gold leaf electroscope that can be used to measure electric charge.

Fig. 15.1

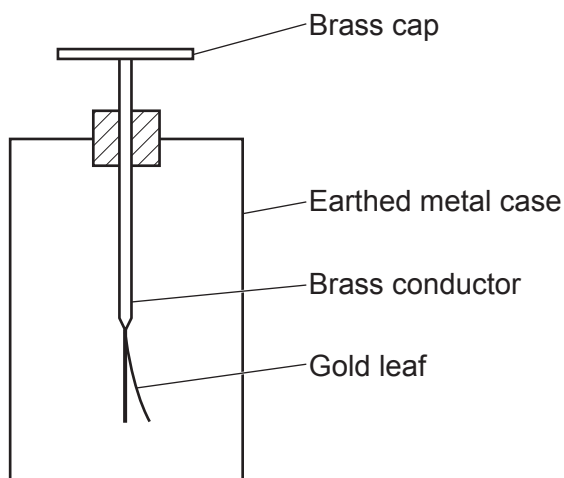

(a) A positively charged rod is rubbed across the brass cap of the gold leaf electroscope.

Complete the sentence to explain how the gold leaf electroscope becomes **positively** charged.

Use words from the list.

Electrons	Gold leaf electroscope	Neutrons	Protons
Positively charged rod			

..... move from the to the

[2]

(b) When the gold leaf electroscope is positively charged, the gold leaf rises.

Fig. 15.2 shows the positively charged gold leaf electroscope.

Fig. 15.2

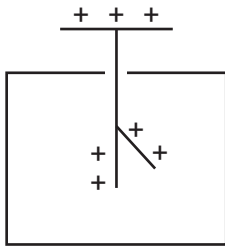

Explain why the gold leaf rises.

.....
..... [1]

(c) A scientist earths the cap of the positively charged gold leaf electroscope by touching it with their finger.

Complete Fig. 15.3 to show what happens to the gold leaf.
Explain your answer.

Fig. 15.3

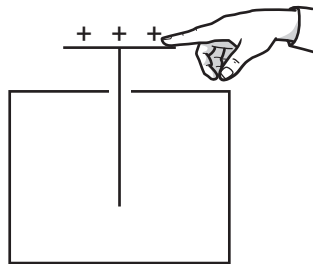

Explanation

.....

.....

..... [2]

16 A student measures the acceleration due to gravity by dropping a ball through a light gate.

The diagram shows the experiment.

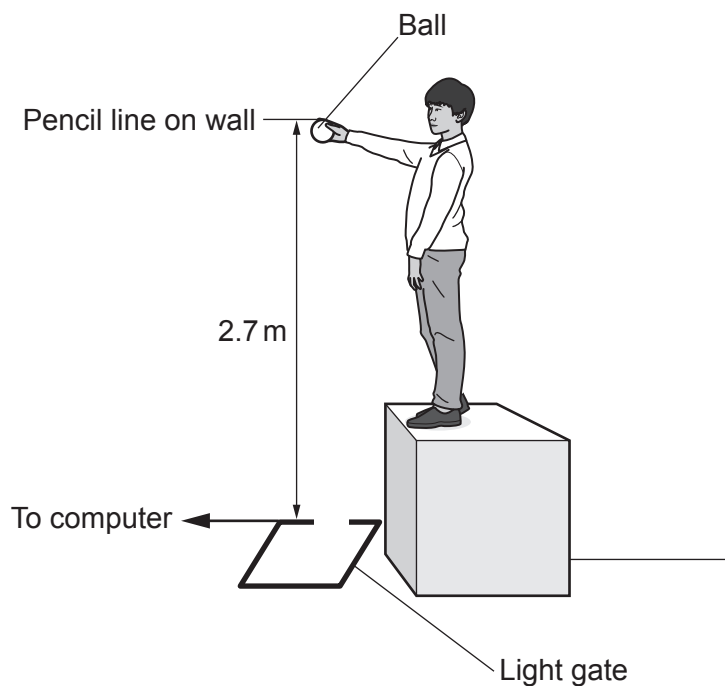

(a) Put the steps in the correct order to describe a method for the experiment.

Write numbers 1–4 in the boxes below. Step 5 has been filled in for you.

- Write down the computer's value for the final velocity.
- Make a pencil line on the wall.
- Measure a height of 2.7 m with a tape measure.
- 5 Use $(\text{final velocity})^2 - (\text{initial velocity})^2 = 2 \times \text{acceleration} \times \text{distance}$ to calculate the acceleration due to gravity.
- Drop the ball through the light gate.

[1]

- (b) Draw lines to match each **source of error** in the experiment to the correct **way to remove the error**.

Source of error

The ball is thrown downwards.

The ball is dropped from the wrong height.

The computer calculates the wrong velocity.

Way to remove the error

Hold the ball in a clamp stand and loosen the clamp to release.

Repeat the same measurement 3 times.

Make sure the ball is dropped through the centre of the light gate.

Make sure the ball is at the same level as the pencil line.

[2]

- (c) The light gate and computer are used to calculate the final velocity of the ball.

- (i) What information does the student have to enter into the computer?

..... [1]

- (ii) The computer displays a final velocity of 7.2 m/s when the student drops the ball from 2.7 m.

Calculate a value for the acceleration due to gravity.

Use the equation: $(\text{final velocity})^2 - (\text{initial velocity})^2 = 2 \times \text{acceleration} \times \text{distance}$

Acceleration due to gravity = m/s² [3]

END OF QUESTION PAPER

ADDITIONAL ANSWER SPACE

If additional space is required, you should use the following lined page(s). The question number(s) must be clearly shown in the margin(s).

A large rectangular area with a vertical solid line on the left side and horizontal dotted lines across the rest of the page, providing space for writing answers.



Copyright Information

OCR is committed to seeking permission to reproduce all third-party content that it uses in its assessment materials. OCR has attempted to identify and contact all copyright holders whose work is used in this paper. To avoid the issue of disclosure of answer-related information to candidates, all copyright acknowledgements are reproduced in the OCR Copyright Acknowledgements Booklet. This is produced for each series of examinations and is freely available to download from our public website (www.ocr.org.uk) after the live examination series. If OCR has unwittingly failed to correctly acknowledge or clear any third-party content in this assessment material, OCR will be happy to correct its mistake at the earliest possible opportunity.

For queries or further information please contact The OCR Copyright Team, The Triangle Building, Shaftesbury Road, Cambridge CB2 8EA.

OCR is part of Cambridge University Press & Assessment, which is itself a department of the University of Cambridge.