

CANDIDATE
NAME

--

CENTRE
NUMBER

--	--	--	--	--

CANDIDATE
NUMBER

--	--	--	--

BIOLOGY

9700/21

Paper 2 Structured Questions AS

May/June 2016

1 hour 15 minutes

Candidates answer on the Question Paper.

No Additional Materials are required.

READ THESE INSTRUCTIONS FIRST

Write your Centre number, candidate number and name on all the work you hand in.

Write in dark blue or black pen.

You may use an HB pencil for any diagrams or graphs.

Do not use staples, paper clips, glue or correction fluid.

DO NOT WRITE IN ANY BARCODES.

Answer **all** questions.

Electronic calculators may be used.

You may lose marks if you do not show your working or if you do not use appropriate units.

At the end of the examination, fasten all your work securely together.

The number of marks is given in brackets [] at the end of each question or part question.

This document consists of **13** printed pages and **3** blank pages.

Answer **all** the questions.

- 1 Table 1.1 shows features of three infectious diseases: malaria, tuberculosis (TB) and cholera. Complete Table 1.1.

Table 1.1

feature	malaria	tuberculosis	cholera
name of pathogen <i>falciparum</i>	<i>Mycobacterium tuberculosis</i>
type of organism	bacterium
method of transmission	drinking water and food contaminated with human faeces

[6]

[Total: 6]

- 2 Macrophages synthesise intracellular enzymes.

Fig. 2.1 is a summary diagram of events that occur in a macrophage.

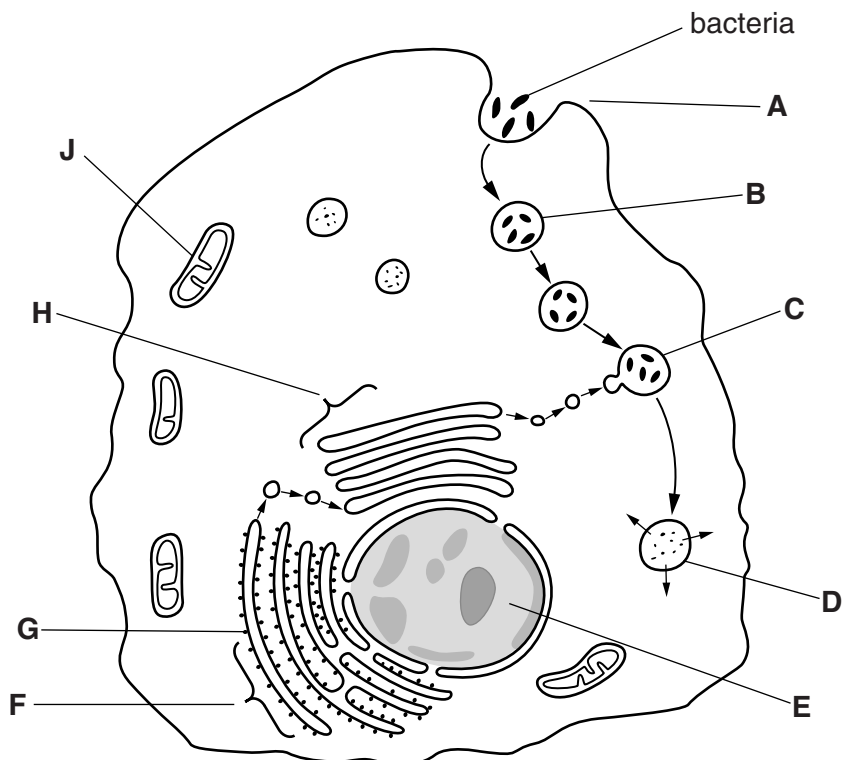

Fig. 2.1

(a) (i) Name the process at **A**.

.....[1]

(ii) Name the stages of protein synthesis that occur at **E** and at **F**.

E

F[2]

(iii) Name organelles **B**, **G**, **H** and **J**.

B

G

H

J[4]

(b) Describe what happens to the bacteria between **C** and **D**.

.....
.....
.....
.....
.....
.....
.....
.....
.....
.....
.....[3]

- 3 A student studied a transverse section of the trachea of a small mammal. The student drew a plan diagram of the section as shown in Fig. 3.1.

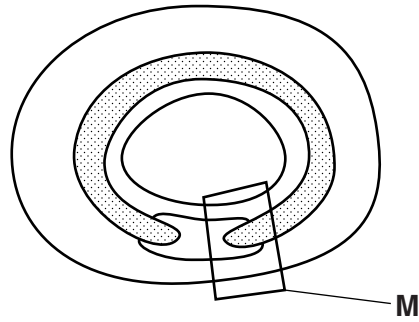

Fig. 3.1

Fig. 3.2 is a photomicrograph of the area labelled **M** in Fig. 3.1.



Fig. 3.2

(a) Name:

- (i) the type of epithelium at **N**

.....[1]

- (ii) the structures at **O**

.....[1]

- (iii) the tissue at **P**.

.....[1]

(b) Smooth muscle in the trachea and in the bronchi relaxes during strenuous exercise.

Suggest the advantages of relaxing this smooth muscle during periods of strenuous exercise.

.....
.....
.....
.....
.....
.....
.....[2]

(c) The walls of the trachea and bronchi contain elastic fibres.

Elastic fibres are made of bundles of the fibrous protein elastin.

- Each molecule of elastin is a single polypeptide.
- The primary structure contains a large proportion of the amino acid glycine.
- Glycine has a hydrophobic R group.
- Glycine does not occur at regular intervals in the polypeptide.
- The polypeptide forms random coils that change shape as the elastic fibres are stretched and recoil.
- Elastin molecules are joined to each other by many covalent bonds to form a cross-linked network.

Describe two ways in which the structure of a collagen molecule **differs** from the structure of an elastin molecule described above.

1
.....
2
.....[2]

[Total: 7]

Researchers determined the rates of transpiration of emergent, canopy and suppressed trees in a forest over a 14 hour period from 06.00 until 20.00 on one day in the summer. The results are shown in Fig. 4.2A. They also recorded changes in light intensity above the canopy over the same time period as shown in Fig. 4.2B.

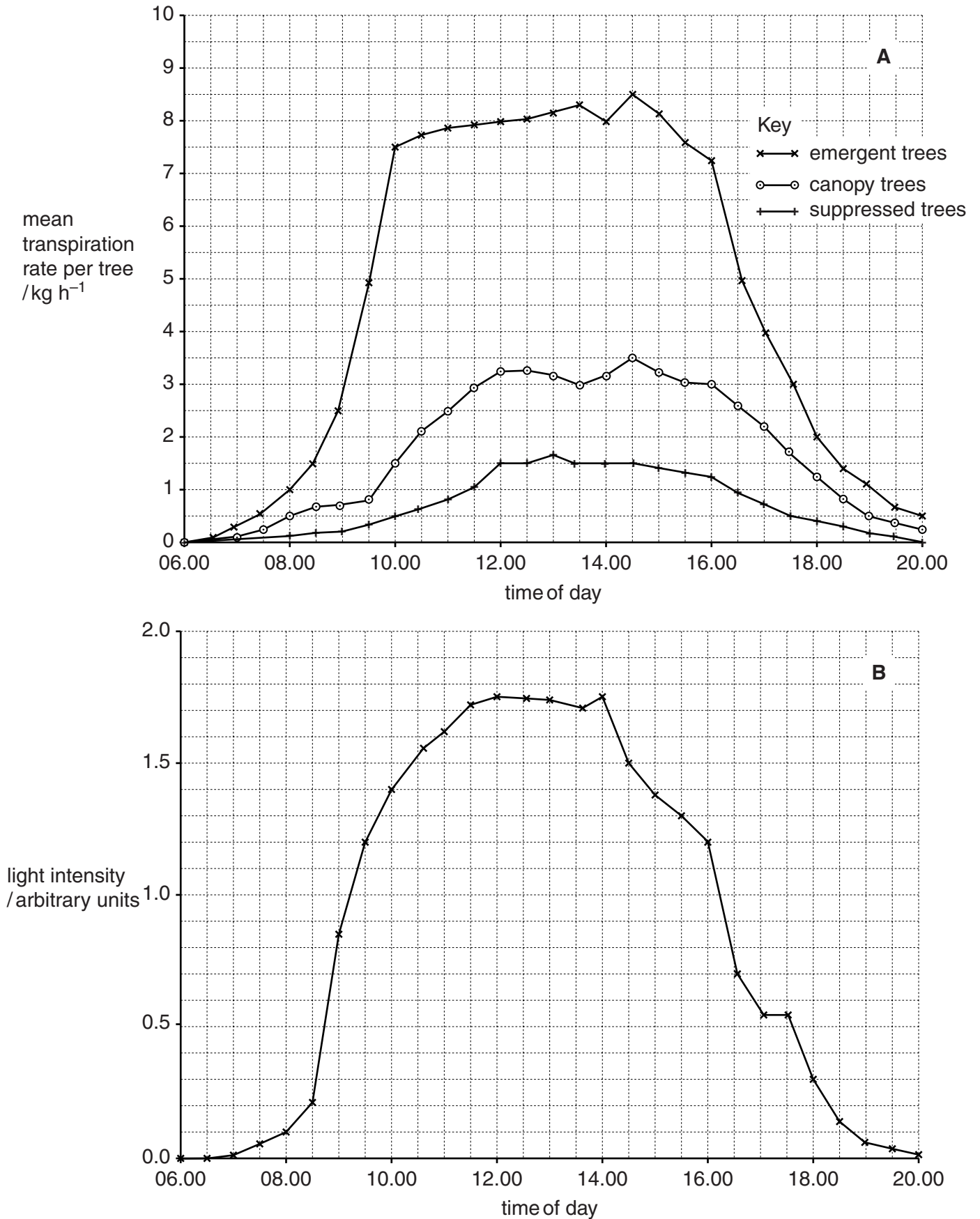

Fig. 4.2

- 6 Fig. 6.1 shows an incomplete diagram of the fluid mosaic model of membrane structure. The diagram shows the cell surface membrane of a eukaryotic cell.

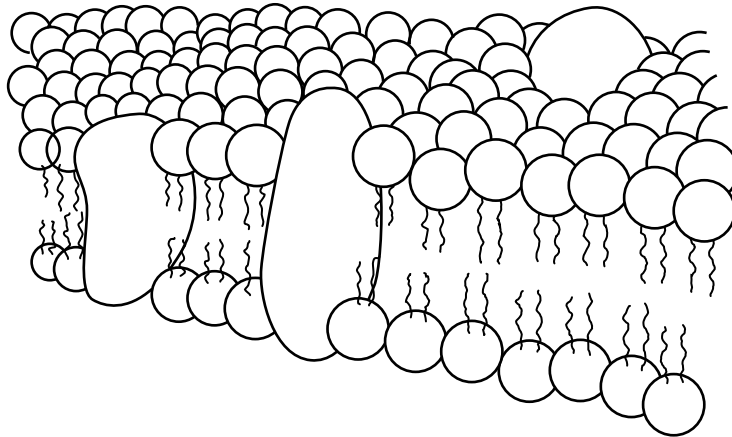

Fig. 6.1

- (a) State what is meant by the term fluid mosaic.

.....
.....
.....
.....[2]

- (b) State the thickness of a cell surface membrane.

.....[1]

- (c) List four features of cell surface membranes of eukaryotic cells that are **not** visible in Fig. 6.1.

1
.....
2
.....
3
.....
4
.....[4]

[Total: 7]

BLANK PAGE

Permission to reproduce items where third-party owned material protected by copyright is included has been sought and cleared where possible. Every reasonable effort has been made by the publisher (UCLES) to trace copyright holders, but if any items requiring clearance have unwittingly been included, the publisher will be pleased to make amends at the earliest possible opportunity.

To avoid the issue of disclosure of answer-related information to candidates, all copyright acknowledgements are reproduced online in the Cambridge International Examinations Copyright Acknowledgements Booklet. This is produced for each series of examinations and is freely available to download at www.cie.org.uk after the live examination series.

Cambridge International Examinations is part of the Cambridge Assessment Group. Cambridge Assessment is the brand name of University of Cambridge Local Examinations Syndicate (UCLES), which is itself a department of the University of Cambridge.