



Rewarding Learning
ADVANCED SUBSIDIARY
 General Certificate of Education
 2018

Centre Number

--	--	--	--	--

Candidate Number

--	--	--	--

Physics

Assessment Unit AS 3A

assessing
 Practical Techniques
 and Data Analysis



SPH31

[SPH31]

THURSDAY 3 MAY, MORNING

TIME

1 hour.

INSTRUCTIONS TO CANDIDATES

Write your Centre Number and Candidate Number in the spaces provided at the top of this page.

Answer **all** the questions in this booklet. Rough work and calculations must also be done in this booklet. Except where instructed, do **not** describe the apparatus or experimental procedures. The Teacher/Supervisor will tell you the order in which you are to answer the questions. One hour is to be spent on four short experimental tests.

After 12 minutes you must stop using the apparatus so that it can be rearranged for the next candidate. At 14 minutes you will be instructed to move to the station for the next question.

At the end of the test a 4 minute period will be provided for you to complete your answer to any question, but you will not have access to the apparatus during this time.

INFORMATION FOR CANDIDATES

The total mark for this paper is 40.

Figures in brackets printed down the right-hand side of pages indicate the marks awarded to each question or part question.

You may use an electronic calculator.

For Examiner's use only		
Question Number	Marks	Remark
1		
2		
3		
4		
Total Marks		

- 2 In this experiment you will investigate the effect of temperature on the resistance of a thermistor.

A thermistor and a thermometer are clamped and submerged in a beaker of water. A circuit is set up to measure the current I through the thermistor and the potential difference V across the thermistor.

- (a) Draw a circuit diagram of the set-up to measure I and V using the correct symbols for all the components.

[3]

- (b) (i) Read the temperature T of the water from the thermometer. Close the switch and read the I and V values. Record your results in **Table 2.1**.

Use the spoon provided to add three spoons of crushed ice into the beaker. Do not adjust any of the apparatus as you add the ice.

Allow the temperature to drop by at least 10°C and obtain a second set of results. Record these in **Table 2.1**. [3]

Table 2.1

$T/^{\circ}\text{C}$	I/mA	V/V	R/Ω

Examiner Only

Marks Remark

(ii) Calculate the resistance of the thermistor at both temperatures and complete the final column of **Table 2.1**.

[3]

(c) From your results explain why the thermistor is said to be a negative temperature coefficient thermistor.

[1]

Examiner Only	
Marks	Remark

- 3 In this experiment you will verify that the magnification is equal to the ratio of the image distance v to the object distance u .

In addition to the converging lens of focal length 200 mm you are provided with an illuminated object, a screen, a metre rule and a 30 cm rule. The illuminated object consists of two crossed lines with a flat circular ring of internal diameter d_o as shown in **Fig. 3.1**. d_o has been measured as 10 mm.

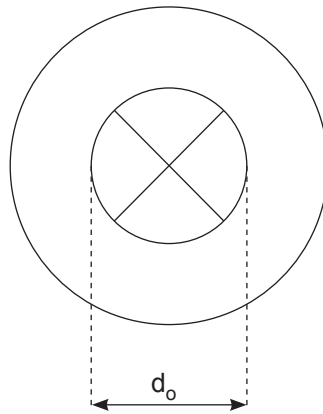

Fig. 3.1

- (a) What range of object distances will produce a **real, enlarged** image?

[2]

- (b) Draw a labelled diagram of the experimental arrangement you will use to verify that the magnification is equal to the ratio of v to u .

[2]

Examiner Only	
Marks	Remark

- (c) Set up the experimental arrangement and obtain an enlarged image of the object on the screen. Measure the internal diameter d_i of the image and record it in **Table 3.1** along with the values of object distance u and image distance v .

Table 3.1

u/mm	v/mm	d_o/mm	d_i/mm
		10	

[3]

- (d) Explain the uncertainty that arises in finding the position of the image.

[1]

- (e) Use the results recorded in **Table 3.1** to calculate values that may be used to verify that the magnification is equal to the ratio of v to u .

[2]

Examiner Only

Marks Remark

- 4 In this experiment you will investigate the relationship between the period of oscillation T of a pendulum and its length l .

Fig. 4.1 shows the arrangement of the apparatus which has been set up for you.

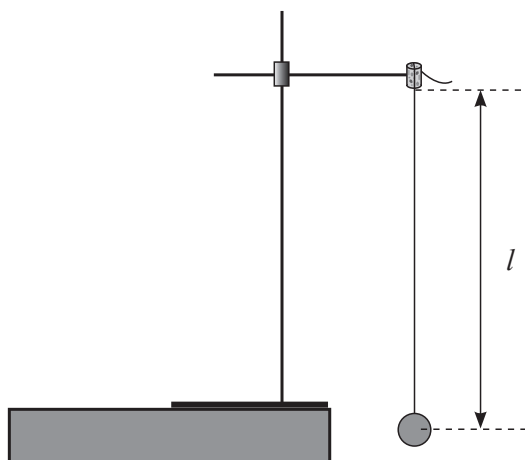

Fig. 4.1 (side view)

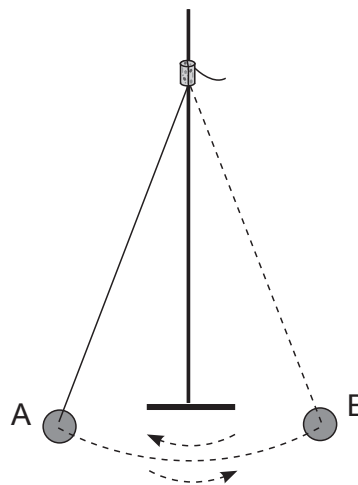

Fig. 4.2 (front view)

The pendulum bob is suspended by a string inserted in a split cork. The length of the string can be adjusted by pulling it through the cork.

The length of the string is measured between the point of suspension and the centre of the bob.

The pendulum is set into oscillation by displacing the pendulum bob a small distance to one side, as shown in **Fig. 4.2**.

The period of oscillation is the time taken for the pendulum to swing from A to B and back to A again as shown in **Fig. 4.2**.

- (a) l has been set at 50.0 cm. Use the stopclock to find a reliable value for T at this length. Shorten the string to a second value of l and repeat. Record all your results in **Table 4.1**.

Table 4.1

l/cm		T/s	T^2/s^2
50.0			

[5]

Examiner Only

Marks Remark

- (b) The relationship between l and T is given by **Equation 4.1**.
 k and n are constants.

$$T^2 = kl^n \qquad \text{Equation 4.1}$$

- (i) Calculate values for T^2 and insert them into the final column of **Table 4.1**. [1]

- (ii) Use your results in **Table 4.1** to choose the best value for n in **Equation 4.1**. Indicate your choice by placing a tick (\checkmark) in the appropriate box.

$n = 1$

$n = \frac{1}{2}$

$n = -2$

Explain your answer.

[2]

- (iii) Use **all** of your results to find a value for k .

$k =$ _____ [2]

THIS IS THE END OF THE QUESTION PAPER

Examiner Only

Marks Remark

Permission to reproduce all copyright material has been applied for.
In some cases, efforts to contact copyright holders may have been unsuccessful and CCEA
will be happy to rectify any omissions of acknowledgement in future if notified.



Rewarding Learning

ADVANCED
General Certificate of Education
2018

Physics

Assessment Unit AS 3A

Practical Techniques and Data Analysis

[SPH31]
THURSDAY 3 MAY

APPARATUS AND MATERIALS LIST

PHYSICS UNIT 3 (AS 3A)
APPARATUS AND MATERIALS REQUIRED FOR PRACTICAL ASSESSMENT

CONFIDENTIAL

This document gives preliminary information on the apparatus and materials required for the AS Practical Assessment.

Information about the apparatus and materials required for this assessment must NOT be communicated to students. If apparatus/materials have their serial code and/or manufacturer specified then it is essential that centres use this exact apparatus/material.

On receipt of this APPARATUS AND MATERIALS LIST, centres must contact Gavin Gray, ggray@ccea.org.uk immediately if they have difficulty in sourcing the specified apparatus or materials.

Teachers will be given detailed instructions for setting up the experiment in the *Confidential Instructions for Physics (Advanced Subsidiary) Practical Test*, to which they will have confidential access from April 2018.

Teachers will have confidential access to a copy of the experimental test two working days (48 hours) before the start of the assessment.

The AS 3 Practical Techniques Assessment is a test of practical skills consisting of 4 short experimental tests (40 marks). The duration of the assessment is 1 hour.

The apparatus in the following list will allow for **one experiment** to be set up for the practical test which makes up questions 1–4. In other words, each set of apparatus (as listed on **pages 4 and 5**) will accommodate four candidates when doing the circus of experiments.

The apparatus can be used for alternative sessions according to the following schedule:

3 May 2018 Physics AS 3A (SPH31)

(Main Session) **9.15 am–10.15 am**

(First Alternative) **10.30 am–11.30 am**

(Second Alternative) **11.45 am–12.45 pm**

(Third Alternative) **1.15 pm–2.15 pm**

(Fourth Alternative) **2.30 pm–3.30 pm**

One set of apparatus for AS 3A (SPH31) will therefore be sufficient for twenty candidates on **3 May** if the Main Session and all four alternatives are used. A laboratory may contain one, two, three or more sets of apparatus. This means that four, eight, twelve or more candidates can be accommodated in the same session. **To maintain the confidentiality of details of the practical tests, candidates entered for any of the alternative sessions must be segregated within the centre so that there can be no communication with candidates who have taken an earlier test in any centre.**

IMPORTANT NOTICE

Centres are urged to order items needed for the Physics Practical Tests from the suppliers as soon as possible.

Question 1

- Gas jar with diameter 4–6 cm, capacity at least 200 ml, mass less than 300 g
- Half metre rule
- Vernier calliper
- Electronic balance capable of reading up to 500 g to nearest 1 g or 0.1 g
- 250 ml beaker
- 150 ml salt water solution (approx. 1.1 g cm^{-3})
- 250 ml graduated cylinder
- Insulating tape

Question 2

- Thermistor EPCOS B57164K471J or similar (KED471). RS 191-2229
- 1.5 V D cell
- Digital milliammeter 0–20 mA to 0.01 mA
- Digital voltmeter 0–20 V to 0.01 V
- Connecting leads with 5 mm plugs at each end $\times 6$
- 250 ml beaker
- Water at room temperature
- Crushed ice
- Retort stand & clamp
- Switch
- Method of clamping the thermistor into retort stand, e.g. component holder with crocodile clips.
- Dessert spoon/soup spoon
- Thermometer with range -10°C to 110°C

Question 3

- 20 cm convex lens and holder
- Constructed illuminated object (washer with internal diameter 10 ± 1 mm) and crosswires as used in 2011 A2 3 shown in **Fig 3.1**
- Screen – plain white paper
- Metre rule
- 30 cm rule

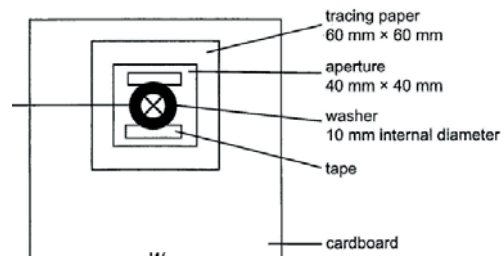

Fig. 3.1

Question 4

- Pendulum bob, string and split cork
- Retort stand, clamp and boss
- Stopclock to 0.01 s
- Metre rule



Rewarding Learning

**ADVANCED SUBSIDIARY (AS)
General Certificate of Education
2018**

Physics

Assessment Unit AS 3A

Practical Techniques and Data Analysis

**[SPH31]
THURSDAY 3 MAY**

**CONFIDENTIAL
INSTRUCTIONS**

1 Confidential Instructions

These instructions will give detailed guidance on setting up and testing the apparatus and materials to be used. **Again, information contained within the Confidential Instructions must not be relayed to candidates under any circumstances.** If at this point, centres find that the testing process produces results different to those specified in the Confidential Instructions, they must contact the CCEA Science Subject Officer (ggray@ccea.org.uk) immediately.

2 Final Apparatus Testing

The practical assessment question paper will be made available to the Head of Physics **two** working days before the timetabled starting time so that teachers and technicians can carry out a final test on the experiments. If on checking the apparatus gives unexpected results, the CCEA Physics Subject Officer should be contacted immediately (ggray@ccea.org.uk). If the problem cannot be resolved, then the centre must e-mail the CCEA Physics Subject Officer stating the centre name and number, the specific nature of the problem and the range of anomalous results produced. CCEA will respond by acknowledging receipt of the e-mail. If you do not receive a response within 24 hours, please contact the CCEA Physics Subject Officer by telephone (028 90261200 Ext 2270) to confirm that CCEA has received your e-mail.

3 Practical Assessment AS 3A

The AS 3A Practical Techniques Assessment is a test of practical skills comprised of 4 short experimental tests. The duration of the assessment is 1 hour. Some of this time will be set aside for supervisors to re-set the apparatus ready for the next candidates. The assessment should be run as a circus of experiments with candidates moving to the next experiment at the designated time. The assessment should be timed as follows:

Questions	Time
Q1 (Short practical test)	12 minutes
Changeover and practical write-up	2 minutes
Q2 (Short practical test)	12 minutes
Changeover and practical write-up	2 minutes
Q3 (Short practical test)	12 minutes
Changeover and practical write-up	2 minutes
Q4 (Short practical test)	12 minutes
Changeover and practical write-up	2 minutes
End of test write-up	4 minutes

At the end of each 12 minute period, candidates must stop using the apparatus. During each 2 minute changeover period candidates may write up anything they have not completed however they will not have access to the apparatus.

At the end of the test a 4 minute period is provided for candidates to complete their answer to any question, however they will not have access to the apparatus.

4 After the Practical Assessments

When the individual exam sessions have finished, please return the AS 3A practical scripts together with the corresponding advice notes to the examinations officer (EO). We will collect these by the day after the examination. If we don't, please contact us immediately to arrange another time for collection.

Where the centre finds that a candidate may have been disadvantaged because the apparatus did not function as intended, the supervising teachers should make a report to the EO. The EO will forward the confidential report on the issue and the candidates affected to the centre support section at CCEA for special consideration. Candidates should be identified by their examination number.

IMPORTANT NOTICE

Centres are urged to order items needed for the Physics Practical Tests from the suppliers as soon as possible.

Question 1

Requirements

- Gas jar with diameter 4–6 cm, capacity at least 200 ml, mass less than 300 g
- Half metre rule
- Vernier callipers
- Electronic balance capable of reading up to 500 g to nearest 1 g or 0.1 g
- 250 ml beaker
- 150 ml salt water solution (approx. 1.1 g cm^{-3})
- 250 ml graduated cylinder (teacher use only)
- Insulating tape

Preparation

Place some insulating tape over the scale of the beaker. Use the graduated cylinder to measure 150 ml of the salt solution and put it into the gas jar.

Place the gas jar, half metre rule, vernier callipers, empty beaker and electronic balance on the bench at workstation. Ensure all instruments are zeroed as appropriate.

Action at changeover

Pour the 150 ml salt solution into the gas jar. Place apparatus as at start of experiment with all instruments zeroed.

Question 2

Requirements

- Thermistor EPCOS B57164K471J or similar (KED471). RS 191–2229
- 1.5V D cell
- Digital milliammeter 0–20 mA to 0.01 mA
- Digital voltmeter 0–20 V to 0.01 V
- Connecting leads with 5 mm plugs at each end × 6
- 250 ml beaker
- Water at room temperature
- Crushed ice
- Retort stand and clamp
- Switch
- Method of clamping the thermistor into retort stand, e.g. component holder with crocodile clips.
- Dessert spoon/soup spoon
- Thermometer with range -10°C to 110°C

Preparation

Set up the circuit shown in **Fig 2.1**.

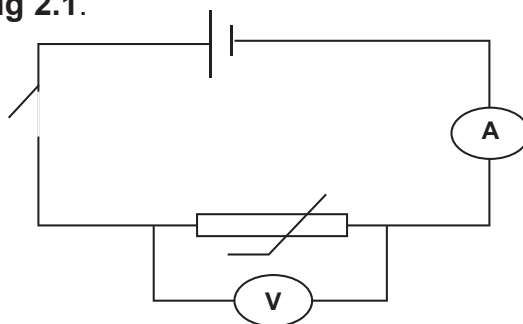

Fig. 2.1

Attach the thermistor to the crocodile clips of a component holder. Clamp the component holder and thermometer in a retort stand and place in a beaker of water at room temperature as shown in **Fig. 2.2(a)** and **(b)**.

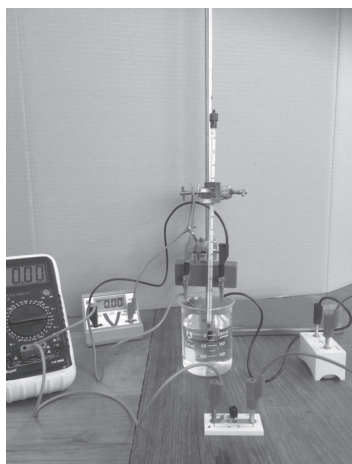

Fig. 2.2(a)

Source: Chief Examiner

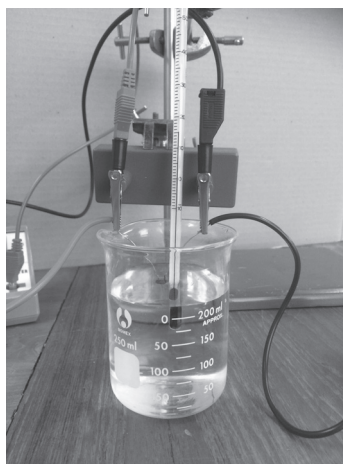

Fig. 2.2(b)

Source: Chief Examiner

Action at Changeover

Replace the iced water in the beaker with water at room temperature. To do this slide the retort stand towards the edge of the bench so that the beaker can be lowered off the edge of the bench as shown in **Fig 2.3**.



Fig 2.3

Source: Chief Examiner

Question 3

Requirements

- 20 cm converging lens and holder
- Constructed illuminated object (washer with internal diameter 10 ± 1 mm) and crosswires as used in 2011 A2 3
- Screen – plain white paper
- Metre rule
- 30 cm rule

Preparation

Illuminated object (washer and cross) construction.

Measure the height H of the centre of the lens, mounted in the lens holder above the surface of the bench. Take a sheet of stiff card and use a sharp knife to cut a square aperture of side 40 mm so that the centre of the square is a distance H from the marked edge of the card. The width W of the card depends on the dimensions of the lens holder.

Cut a piece of tracing or greaseproof paper about 60 mm square. In the centre of this square use a fine felt tip pen (or similar) to mark an “X” with the arms at least 10 mm long. Place the washer over the “X” so that the intersection of the arms is at the centre of the circular hole in the washer. Using transparent self-adhesive tape, attach the washer to the tracing paper. Avoid covering any part of the hole in the washer. Place the tracing paper on the card so that the washer is at the centre of the 40 mm square aperture, with the washer inside the opening. Tape the tracing paper to the cardboard. The completed object is illustrated in **Fig 3.1**

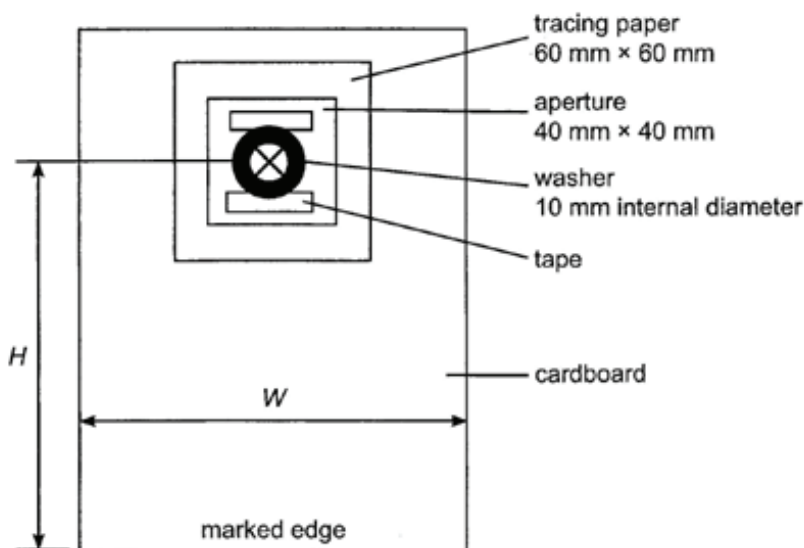

Fig. 3.1 Washer and “X” object (not to scale)

Place apparatus at workstation. Check that the magnification of the object is approximately 2 when the object distance is 30 cm.

Action at Changeover

Dismantle all apparatus and leave as at start of experiment.

Question 4

Requirements

- Pendulum bob, string and split cork
- Retort stand, clamp and boss
- Stopclock to 0.01 s
- Metre rule

Preparation

Tie the pendulum bob to the end of the string. Thread the pendulum string through the split cork. Position the split cork in the jaws of the clamp. Set the length of the pendulum to be 0.500 m. Leave the metre rule and stopclock beside the pendulum.

Action at Changeover

Return the length of the pendulum to 0.500 m and rezero the stopclock.

