



Rewarding Learning

General Certificate of Secondary Education
2016

Centre Number

--	--	--	--	--

Candidate Number

--	--	--	--	--

Science: Physics

Unit 2

Foundation Tier



GPH21

[GPH21]

FRIDAY 24 JUNE, MORNING

TIME

1 hour 30 minutes.

INSTRUCTIONS TO CANDIDATES

Write your Centre Number and Candidate Number in the spaces provided at the top of this page.

You must answer the questions in the spaces provided.

Do not write outside the box, around each page or on blank pages.

Complete in blue or black ink only. **Do not write with a gel pen.**

Answer **all six** questions.

INFORMATION FOR CANDIDATES

The total mark for this paper is 90.

Figures in brackets printed down the right-hand side of pages indicate the marks awarded to each question or part question.

Quality of written communication will be assessed in Question **2(c)(ii)**.

9868



24GPH2101

- 1 (a) The diagram below shows four of the seven members of the electromagnetic spectrum. They are arranged in order of increasing wavelength.

Gamma waves		Ultraviolet light		Infrared light		Radio waves
-------------	--	-------------------	--	----------------	--	-------------

Short wavelength  Long wavelength

- (i) Identify the three missing members of the electromagnetic spectrum by writing their names in the appropriate parts of the diagram. [3]

Different members of the electromagnetic spectrum have different uses.

- (ii) Draw a line between appropriate points below to join the wave with its use.

Wave

Gamma waves



Ultraviolet light



Infrared light



Radio waves



Use

Detect forged banknotes

Long distance communication

TV remote controls

Sterilisation of medical equipment

[4]



(b) One kind of earthquake wave is called an L-wave.

In L-waves the particles of the material vibrate perpendicular to the direction of propagation. A particular L-wave has a frequency of **0.002 Hz** and a wavelength of **2 500 000 m**.

(i) Which **one** of the following statements about L-waves is true?
Tick (✓) the appropriate box.

L-waves are transverse.

L-waves are longitudinal.

L-waves are neither transverse nor longitudinal.

[1]

(ii) Explain what is meant by a wavelength of **2 500 000 m**.

[2]

(iii) Use the information above to calculate the speed of this L-wave. Give your answer in m/s.

You are advised to show clearly how you get your answer.

Speed = _____ m/s [4]

[Turn over



- (c) Ultrasound can be used to measure the diameter of the head of a baby in the womb. The ultrasound is passed through the womb and the baby's head. The time for the ultrasound to travel from **B** to **A** is measured.

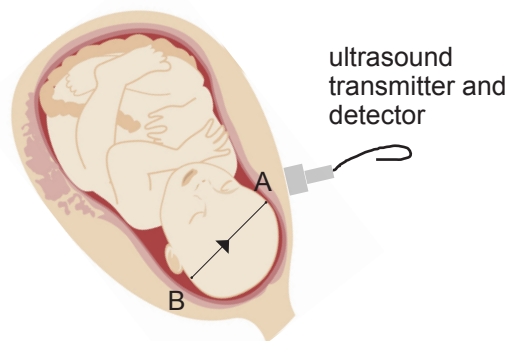

© Lorelyn Medina / Hemera / Thinkstock

- (i) What name is given to the reflection of a sound wave?

_____ [1]

- (ii) It takes **0.00006** seconds for the ultrasound to travel from point B to point A. Ultrasound travels at a speed of **1500 m/s** in a baby's head. Calculate the width of the baby's head. Give your answer in m.

You are advised to show clearly how you get your answer.

Width of baby's head = _____ m [4]



(iii) Explain why it is better to use ultrasound rather than X-rays when monitoring the development of a baby in the womb.

[1]

9868

[Turn over



24GPH2105

- 2 (a) Two mirrors, M1 and M2, are placed at right angles to one another. The diagram below shows a ray of light incident on mirror M1 at point A.

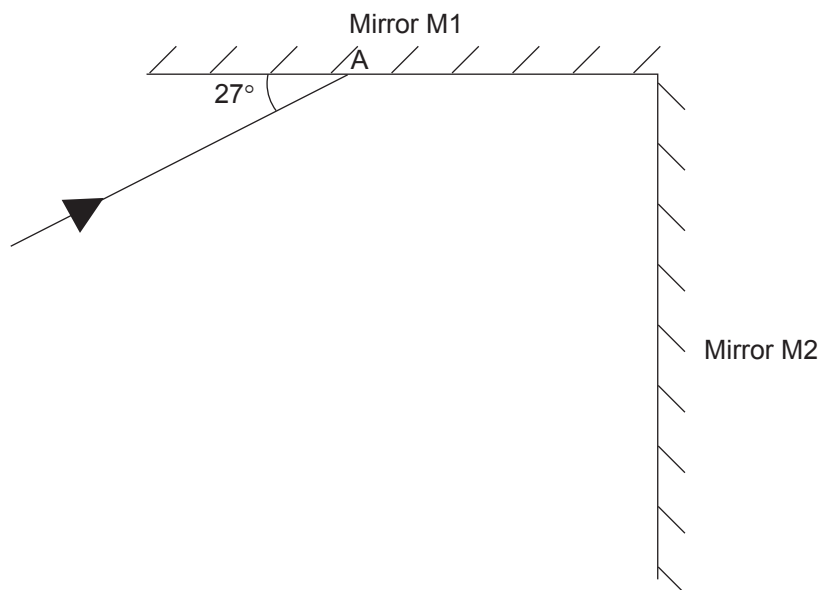

- (i) Calculate the angle of reflection at point A.

Angle of reflection = _____ ° [1]

- (ii) On the diagram above draw, as accurately as you can, the reflected ray from A and from mirror M2. [2]



(b) The diagram below shows a ray of light passing through a rectangular glass block.

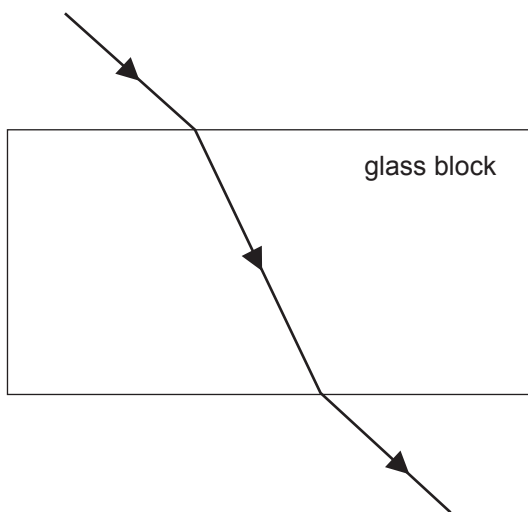

(i) What name is given to the bending of the light when it passes from air into glass?

_____ [1]

(ii) **Using a ruler** draw the normal at the point where the light enters the glass. Label the normal with the letter "N".

[1]

(iii) Mark **clearly** on the diagram the angle of incidence in air with the letter "i" and the angle of refraction in the glass with the letter "r".

[1]

(iv) What causes the light to change direction in the way shown in the diagram when it passes from air into glass?

_____ [2]

[Turn over



(c) (i) State carefully what is meant by the focal length of a converging lens.

[1]



- 3 (a) A student was given a resistance-meter, which measures resistance directly, and a length of nichrome resistance wire. She connected the circuit shown below and recorded the resistance of various lengths of the wire.

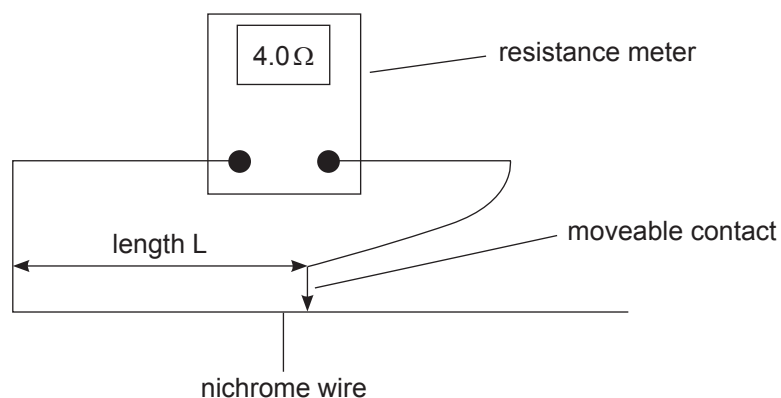

Her results are recorded in the table below.

Length of wire/m	0.00	0.25	0.50	0.75	1.00
Resistance/ Ω	0.0	4.0	7.0	12.0	17.0



- (i) Using the results in the table and the grid below plot a graph of the points and draw the **line of best fit**.

[4]

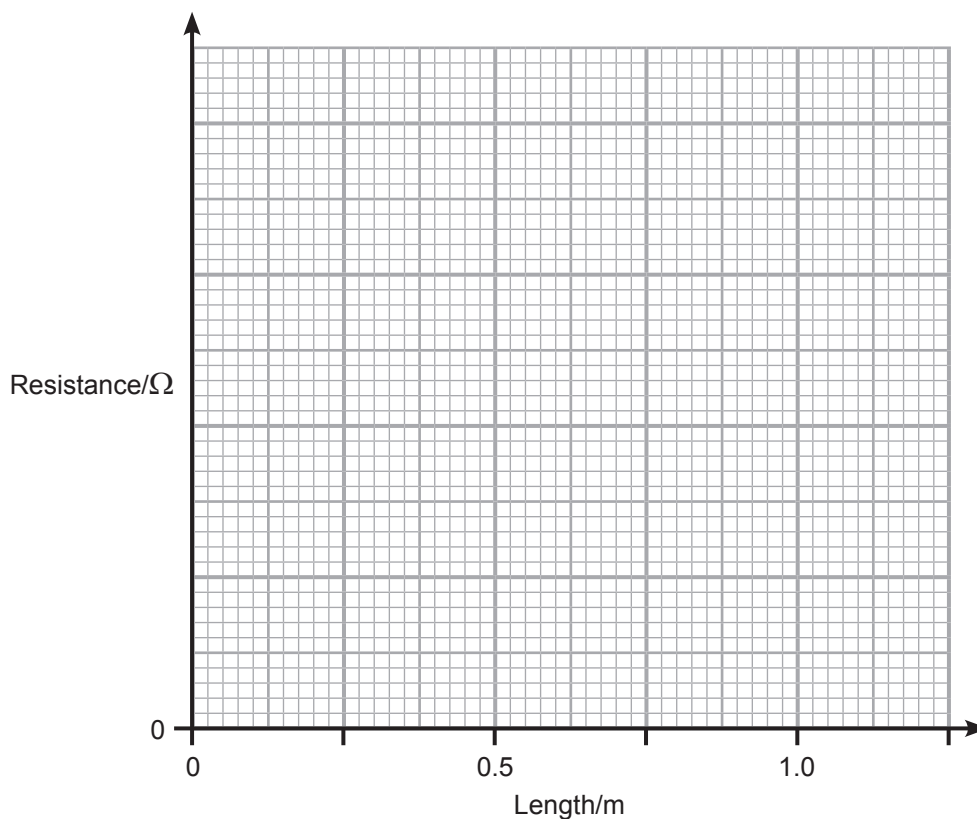

- (ii) The relationship between the resistance R and length L of the wire is of the form

$$R = k \times L$$

Explain how you could obtain the value of k from the graph.

[1]

- (iii) Using your graph find the value of k and include a unit for it.

$k =$ _____ [2]

[Turn over



- (b) Nichrome resistance wire is often used to make the heating elements for electric heaters.

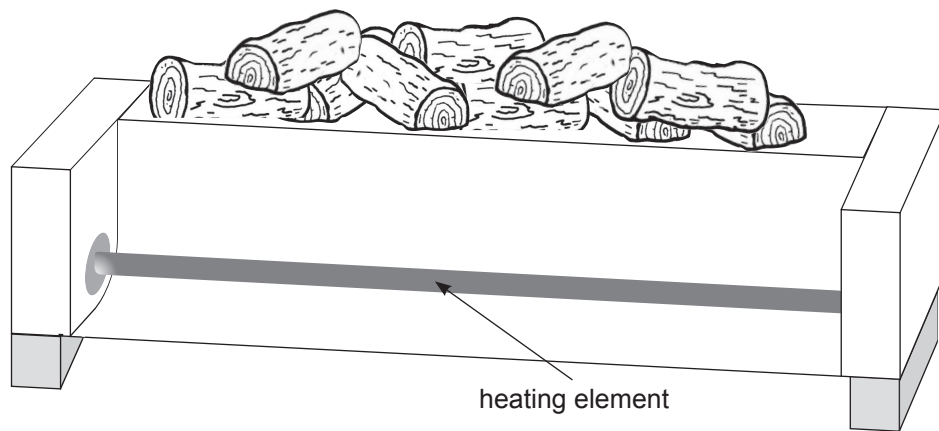

© CCEA

The heater has an electric power rating of 720 W when operated from a 240 V mains supply.

- (i) Using the equation for electrical power calculate the current flowing through the heating element.

You are advised to show clearly how you get your answer.

Current = _____ A [2]



- (ii) Using your answer to part (b)(i) calculate the resistance of the nichrome wire used in the heating element.

You are advised to show clearly how you get your answer.

Resistance = _____ Ω [2]

- (iii) The nichrome wire used is known to have a resistance of 40Ω per metre of length. What length of wire is required to make the heating element?

Length = _____ m [2]

[Turn over



(c) The circuit below was set up.

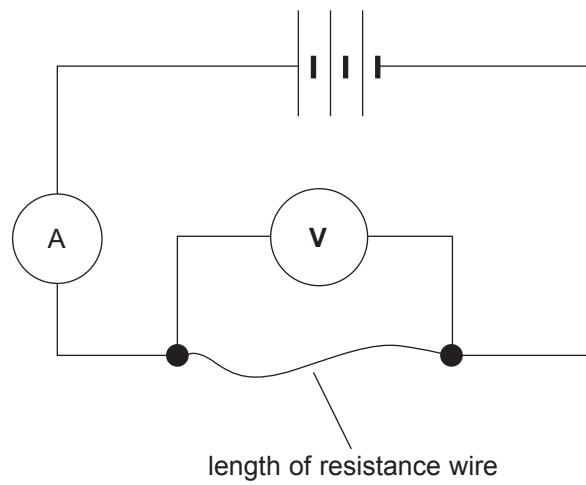

The ammeter read 0.2A and the voltmeter 4.8V which meant that the wire had a resistance of $24\ \Omega$.

The wire was removed and shaped into a circle with the voltmeter connected across the diameter of the circle as shown below.

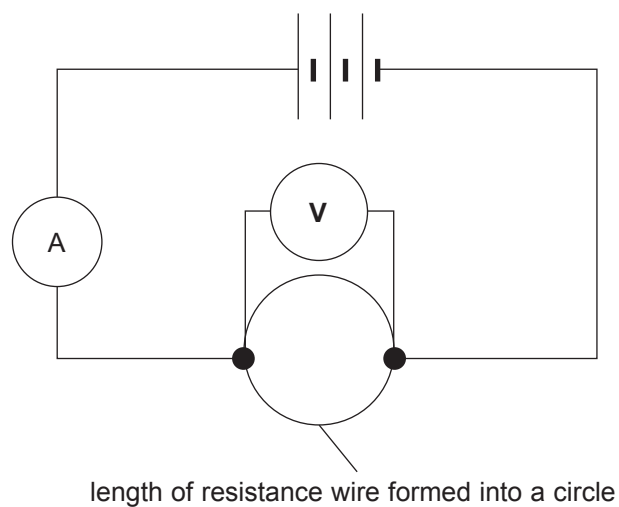

(i) What would the voltmeter now read?

Voltmeter reading = _____ V [1]

(ii) Explain how you arrived at your voltmeter reading.

_____ [1]

(iii) What would the resistance of each semicircle or half of the wire be?
Remember the complete wire had a resistance of $24\ \Omega$.

Resistance of each half = _____ Ω [1]

(iv) Now calculate the resistance of the wire in the circuit when it is formed into a circular loop.

Resistance of circular wire loop = _____ Ω [2]

(v) What would the ammeter now read?
Remember the original ammeter reading was 0.2A .

Ammeter reading = _____ A [2]

[Turn over



- 4 (a) The diagram below represents the distribution network for electricity from the power station to users such as households.

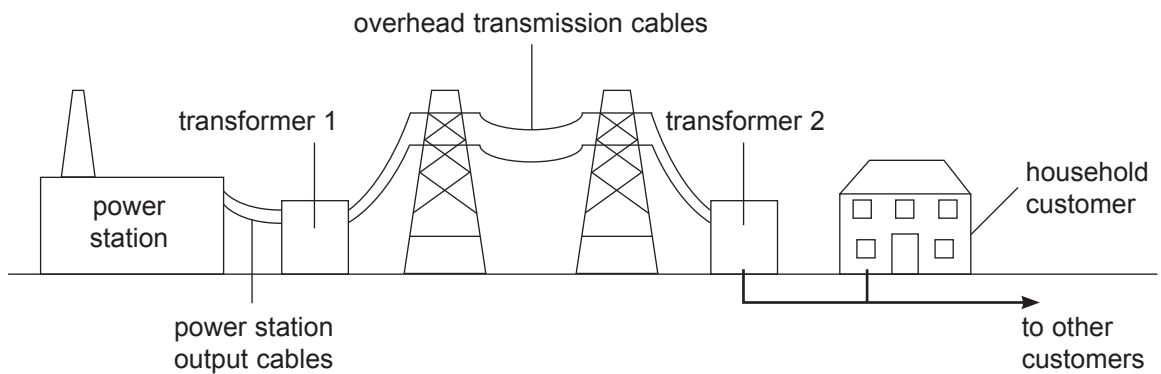

© CCEA

- (i) What type of transformer is transformer 1?

_____ [1]

- (ii) What type of transformer is transformer 2?

_____ [1]

- (iii) Explain fully why transformer 2 is used at the position shown.

_____ [2]



(b) The diagram below shows a simple electromagnet.

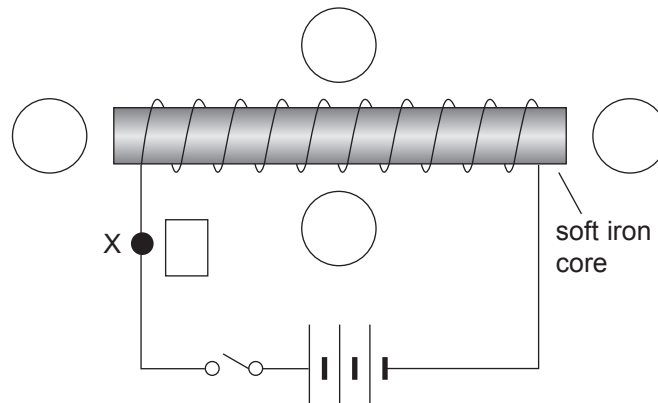

© CCEA

- (i) The switch is closed. At the point marked X show the direction of the current flow by drawing an arrow in the box beside it. [1]
- (ii) On the soft iron core mark clearly the magnetic North and South poles. [1]
- (iii) The circles represent the position of a magnetic compass. Mark an arrow in each of the circles to show the direction of the magnetic field at each position. [2]
- (iv) The wire used to wind the coil of the electromagnet is insulated. Explain why this must be the case.

[2]



(c) The diagram below shows a simple generator.

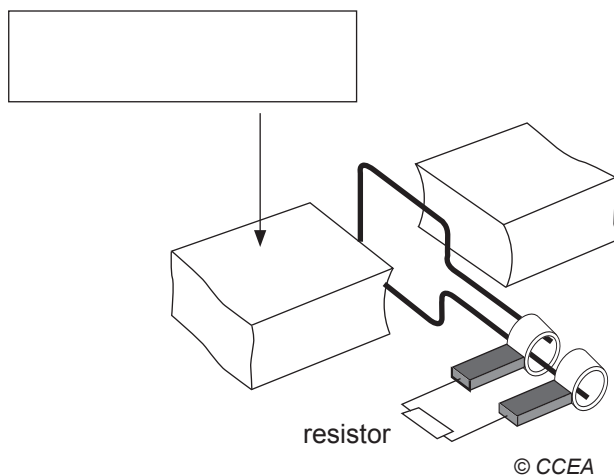

(i) Name the part marked by the arrow. Write your answer in the box provided. [1]

(ii) When the coil is rotated a current passes through the resistor. What type of current is produced, a.c. or d.c.?

_____ [1]



5 (a) The diagram below shows our Sun and the planets that make up the Solar System.

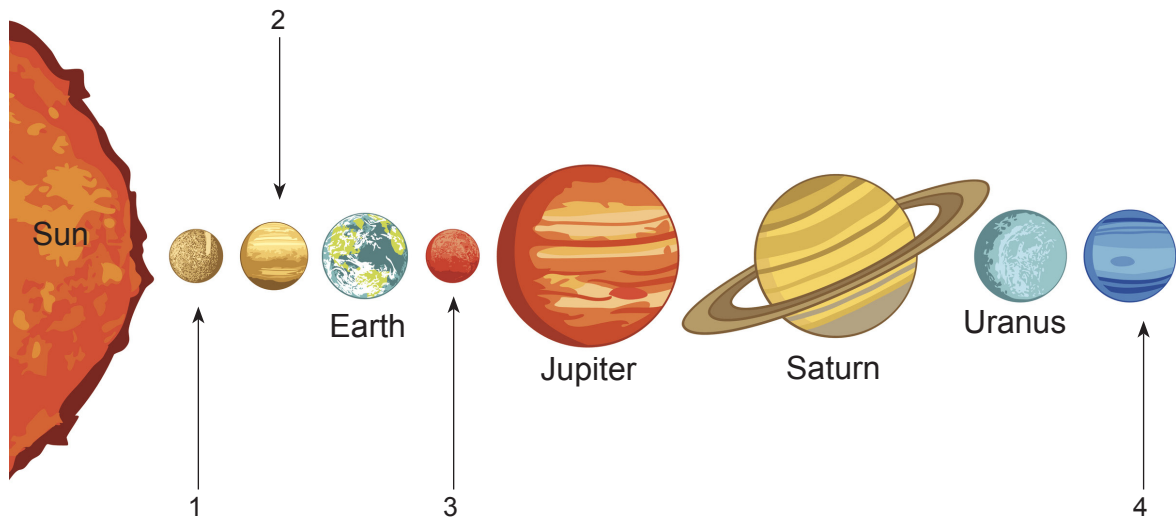

© sntpzh / iStock / Thinkstock

(i) Name the planets marked by numbers.

1 _____

2 _____

3 _____

4 _____

[4]

(ii) What provides the centripetal force that keeps planets in orbit?

[1]

(iii) The Solar System was probably formed from a large cloud of material known as a nebula. Name one piece of evidence that supports this view.

[1]



(b) Although we cannot travel to stars we know they are mainly composed of two gases.

(i) Name these two gases.

1. _____ 2. _____ [2]

(ii) How do we know that stars are mostly composed of these two gases?

_____ [1]

(iii) Stars like our Sun produce very large amounts of energy. What is the name of the process responsible for this energy production?

_____ [1]

[Turn over



6 (a) The diagram below shows a cross section through the Earth.

- (i) On the diagram name the four layers into which the Earth is divided. Write your answers in the boxes provided. Choose your answers from the words below.

outer core	crust	mantle
atmosphere	inner core	ocean

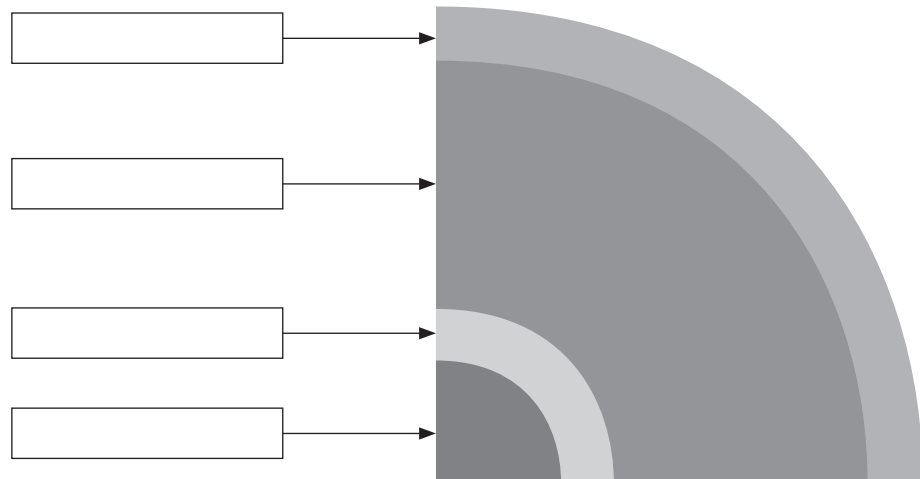

© CCEA

[4]

- (ii) What name is given to the crust and the solid portion of the upper mantle?

_____ [1]

- (iii) What two metals are the constituents of the innermost layers?

_____ and _____ [2]



(b) The rigid outermost shell of the Earth is broken up into sections as shown below. These sections are known as tectonic plates.

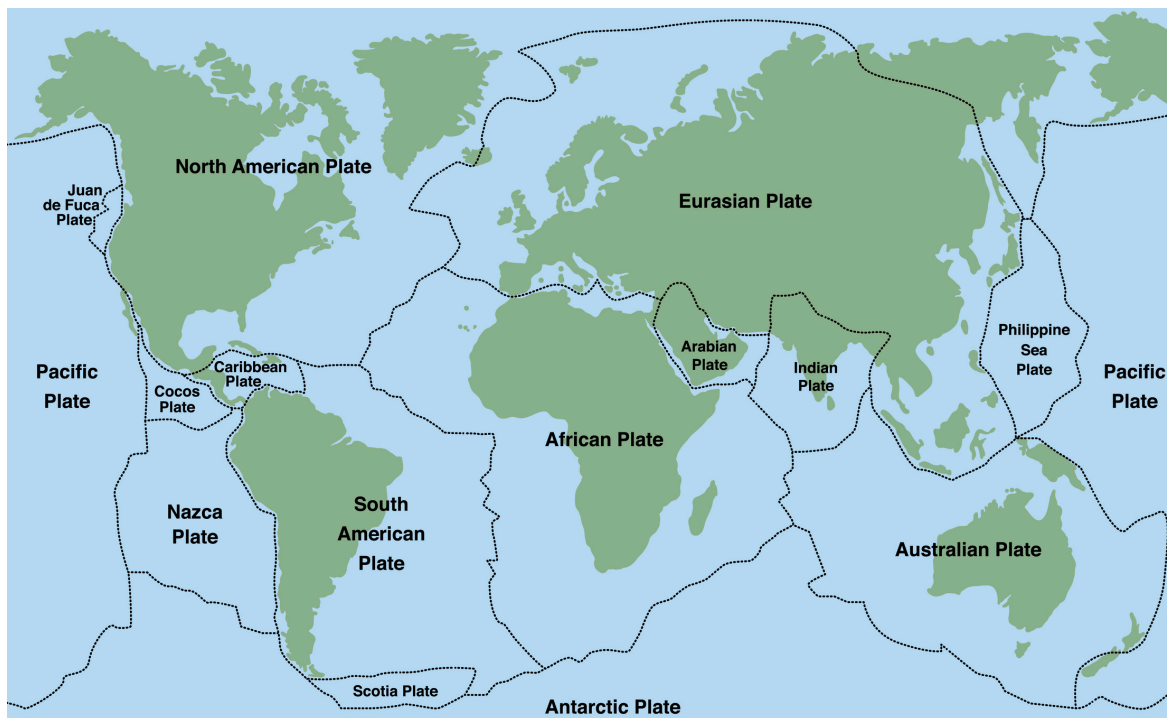

© Peter Hermes Furian / iStock / Thinkstock

Explain how earthquakes occur at some plate boundaries.

[3]

THIS IS THE END OF THE QUESTION PAPER



DO NOT WRITE ON THIS PAGE

For Examiner's use only	
Question Number	Marks
1	
2	
3	
4	
5	
6	

Total Marks	
--------------------	--

Examiner Number

Permission to reproduce all copyright material has been applied for.
In some cases, efforts to contact copyright holders may have been unsuccessful and CCEA will be happy to rectify any omissions of acknowledgement in future if notified.

203528



24GPH2124