



General Certificate of Secondary Education
2016

Centre Number

--	--	--	--	--

Candidate Number

--	--	--	--	--

Science: Physics

Unit 2

Higher Tier



[GPH22]

GPH22

FRIDAY 24 JUNE, MORNING

TIME

1 hour 45 minutes.

INSTRUCTIONS TO CANDIDATES

Write your Centre Number and Candidate Number in the spaces provided at the top of this page.

You must answer the questions in the spaces provided.

Do not write outside the box, around each page or on blank pages.

Complete in blue or black ink only. **Do not write with a gel pen.**

Answer **all six** questions.

INFORMATION FOR CANDIDATES

The total mark for this paper is 115.

Figures in brackets printed down the right-hand side of pages indicate the marks awarded to each question or part question.

Quality of written communication will be assessed in Questions **2(b)(ii)** and **4(a)**.



1 (a) One kind of earthquake wave is called an L-wave.

In L-waves the particles of the material vibrate perpendicular to the direction of propagation. A particular L-wave has a frequency of **0.002 Hz** and a wavelength of **2500 km**.

(i) Which **one** of the following statements, about L-waves, is true?
Tick (✓) the appropriate box.

L-waves are transverse.

L-waves are longitudinal.

L-waves are neither transverse nor longitudinal.

[1]

(ii) Explain what is meant by a frequency of 0.002 Hz.

[2]

(iii) Use the information above to calculate the speed of this L-wave. Give your answer in m/s.

You are advised to show clearly how you get your answer.

Speed = _____ m/s [4]



(b) Ultrasound can be used to measure the diameter of the head of a baby in the womb. When ultrasound reaches the baby's head at A, some ultrasound is reflected back to the detector and produces pulse A on the CRO. Some ultrasound passes through the head to point B, and is reflected back to the detector. This reflection produces pulse B on the CRO.

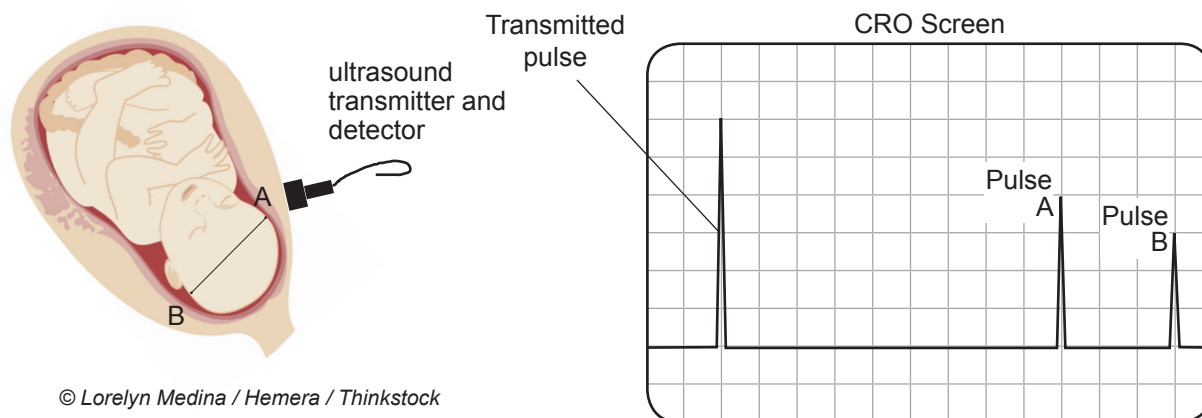

© Lorelyn Medina / Hemera / Thinkstock

(i) What name is given to the reflection of a sound wave?

_____ [1]

The CRO is adjusted so that each horizontal division on the diagram above corresponds to a time of 40 microseconds.

(ii) How long is the time interval between the arrival of pulse A and the arrival of pulse B at the detector? Give your answer in microseconds.

You are advised to show clearly how you get your answer.

Time interval = _____ microseconds [2]

[Turn over



(iii) How long does it take for the ultrasound to travel from one side of the baby's head to the other? Give your answer in microseconds.

You are advised to show clearly how you get your answer.

Time to travel from B to A _____ microseconds [1]

Ultrasound travels at a speed of **1500 m/s** in a baby's head.

(iv) Use your answer to part (iii) to calculate the width of the baby's head from A to B. Give your answer in cm.

(1 microsecond = 1×10^{-6} s).

You are advised to show clearly how you get your answer.

Width of baby's head = _____ cm [5]



- (v) Explain why it is better to use ultrasound rather than X-rays when monitoring the development of a baby in the womb.

[1]

- (c) The diagram below shows four of the seven members of the electromagnetic spectrum. **They are not arranged in any particular order.**

Infrared light	Ultraviolet light	Gamma waves	Radio waves
----------------	-------------------	-------------	-------------

Identify the **three missing members** of the electromagnetic spectrum by writing their names in the appropriate part of the table below.

Name of wave	Wavelength/m
	3×10^{-2}
	6×10^{-7}
	1×10^{-9}

[3]

[Turn over



2 (a) The diagram below shows a ray of light passing through a rectangular glass block.

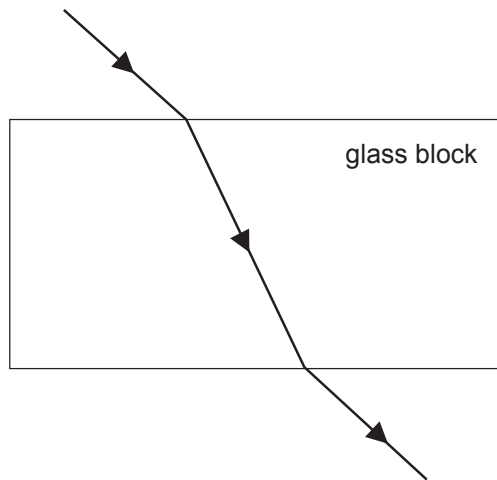

(i) What name is given to the bending of the light when it passes from air into glass?

_____ [1]

(ii) **Using a ruler** draw the normal at the point where the light enters the glass. Label the normal with the letter "N". [1]

(iii) Mark **clearly** on the diagram the angle of incidence in air with the letter "i" and the angle of refraction in the glass with the letter "r". [1]

(iv) What causes the light to change direction in the way shown in the diagram when it passes from air into glass?

_____ [2]

(b) (i) State carefully what is meant by the focal length of a converging lens.

_____ [1]



- (c) The **full scale** diagram below shows a converging lens and an object. Each principal focus is marked with an F.

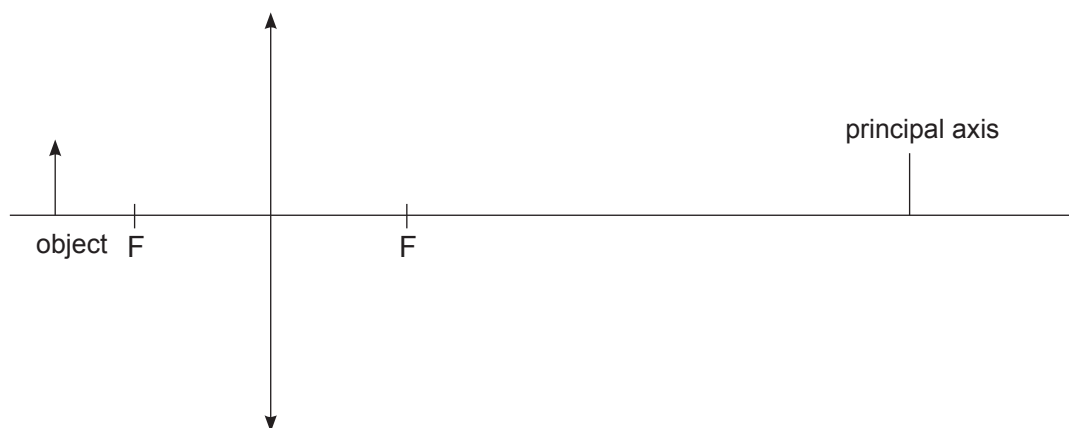

- (i) **Using a ruler**, carefully draw **two** rays on the diagram to find the position of the image.

Label the image with the letter I.

[3]

- (ii) Place arrows on all the rays to show their direction.

[1]

The magnification of an image, M , is defined by the equation:

$$M = \frac{\text{height of the image}}{\text{height of the object}}$$

- (iii) Calculate the magnification of the image in your ray diagram.

You are advised to show clearly how you get your answer.

Magnification = _____ [2]





(iv) Is this image real? Explain your answer.

[2]

[Turn over

9869



28GPH2209

- 3 (a) A student was given a resistance meter, which measures resistance directly, and a length of nichrome resistance wire. She connected the circuit shown below and recorded the resistance of various lengths of the wire.

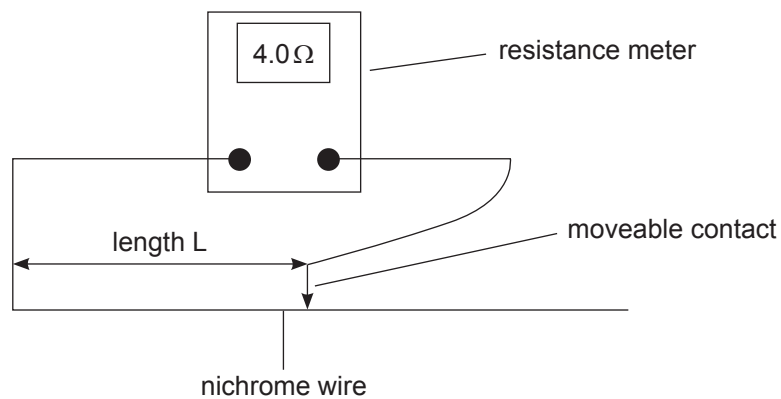

Her results are recorded in the table below.

Length of wire/m	0.00	0.25	0.50	0.75	1.00
Resistance/ Ω	0.0	4.0	7.0	12.0	17.0



- (i) Using the results in the table and the grid below plot a graph of the points and draw the **line of best fit**.

[4]

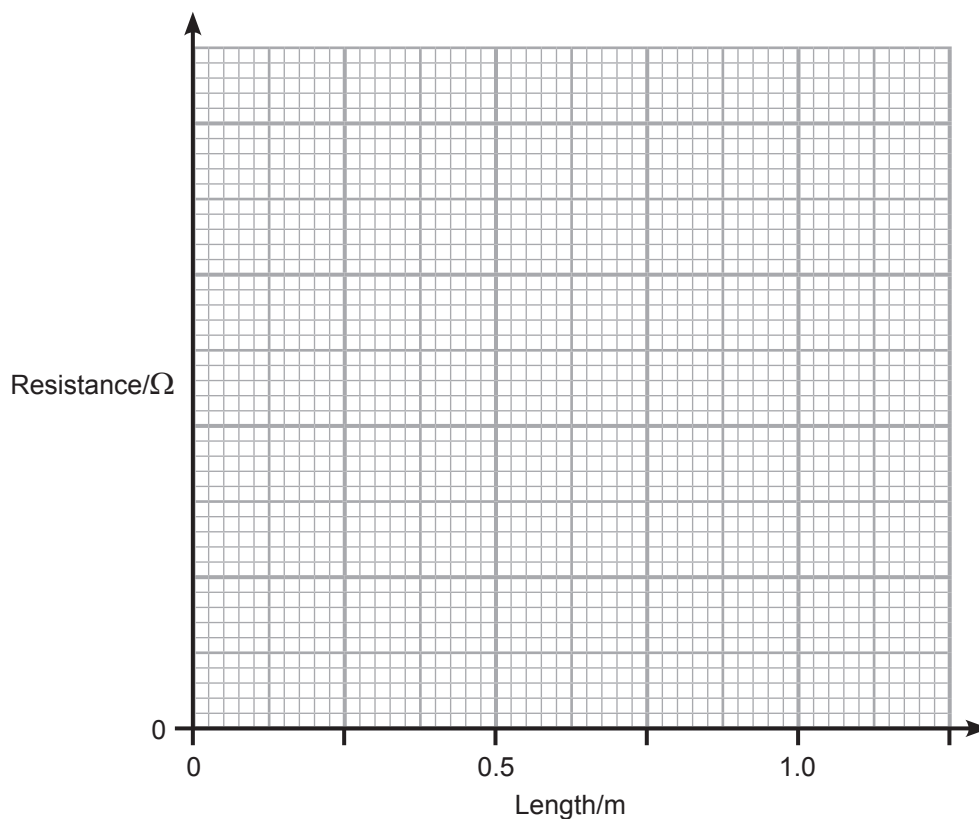

- (ii) The relationship between the resistance R and length L of the wire is of the form

$$R = k \times L$$

Explain how you could obtain the value of k from the graph.

[1]

- (iii) Using your graph find the value of k and include a unit for it.

$k =$ _____ [2]

[Turn over



- (b) Nichrome resistance wire is often used to make the heating elements for electric heaters.

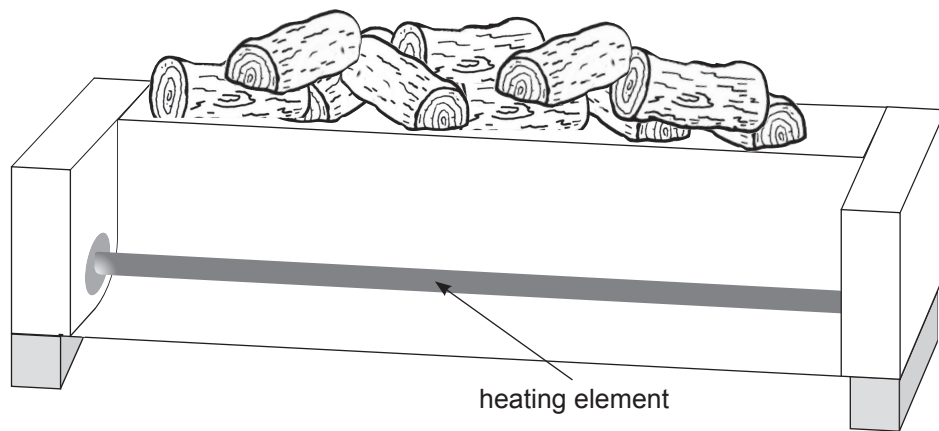

© CCEA

The heater has an electric power rating of 720 W when operated from a 240 V mains supply.

- (i) Calculate the resistance of the nichrome wire used in the heating element.

You are advised to show clearly how you get your answer.

Resistance = _____ Ω [4]



- (ii) The nichrome wire used is known to have a resistance of $40\ \Omega$ per metre of length. What length of wire is required to make the heating element?

Length = _____ m [2]

The production company have decided to use wire of double the cross-sectional area of the previous wire.



original wire
cross-sectional
area 1 unit

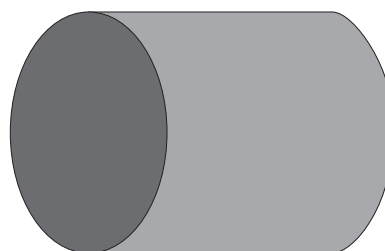

new wire
cross-sectional
area 2 units

© CCEA

- (iii) What effect will using this new wire have on the resistance of the heating element if the length of the new wire used is the same as that of the original wire?

_____ [1]

- (iv) To have a heating element of the same resistance as before what length of the new wire compared to the original wire is needed?

_____ [1]



(c) The circuit below was set up.

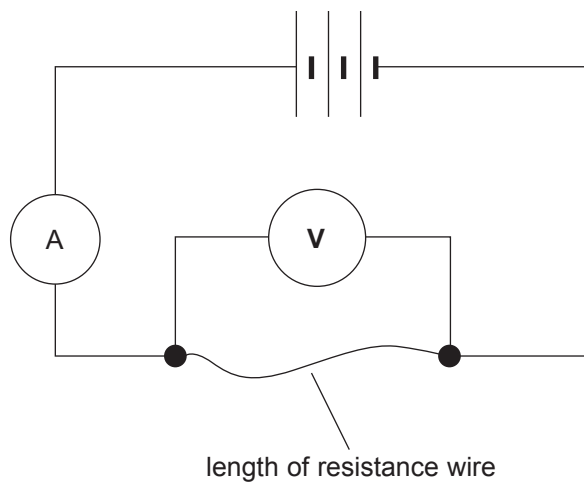

The ammeter read 0.2A and the voltmeter 4.8V which meant that the wire had a resistance of $24\ \Omega$.

The wire was removed and shaped into a circle with the voltmeter connected across the diameter of the circle as shown below.

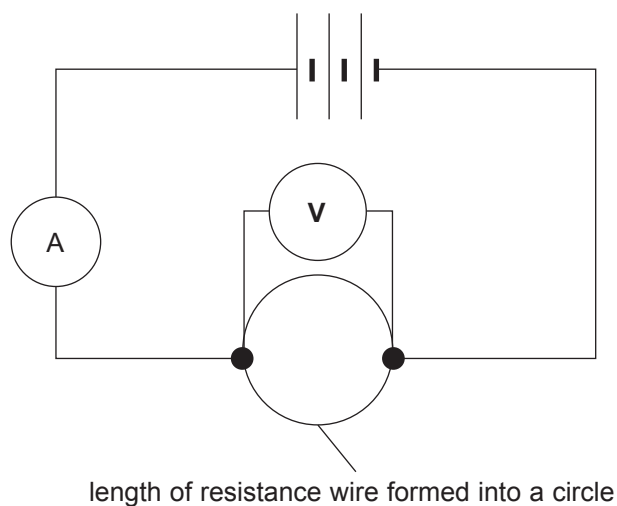

(i) What would the voltmeter now read?

Voltmeter reading = _____ V [1]

(ii) Explain how you arrived at your voltmeter reading.

_____ [1]

(iii) What would the ammeter now read?

Remember the complete wire had a resistance of $24\ \Omega$.

Ammeter reading = _____ A [1]

(iv) Explain how you arrived at your ammeter reading.

_____ [2]

[Turn over



- 4 (a) The oil industry pumps crude oil through many kilometres of pipeline. To measure the volume of oil flowing in the pipeline an electromagnetic meter is used. The diagram shows the basic construction of such a meter.

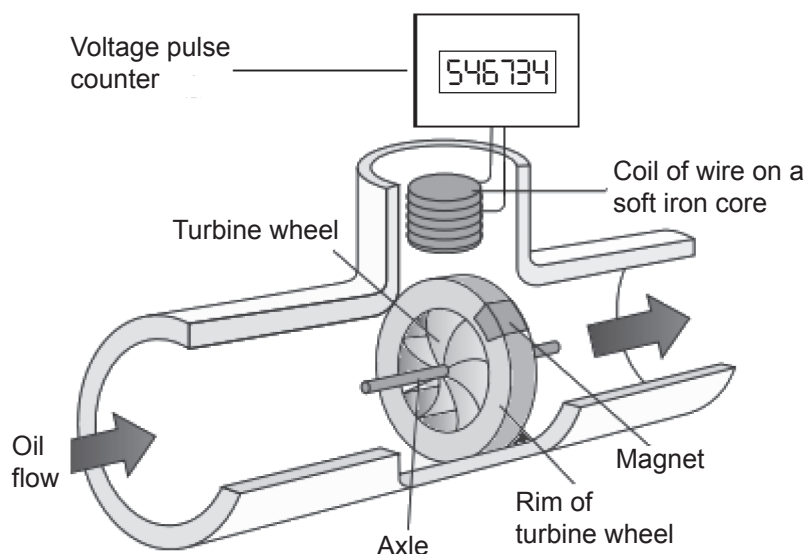

© Cyberphysics http://www.cyberphysics.co.uk/Q&A/KS4/magnetism/EMI/questions_EMI.html

You are asked to explain how the meter works by:

- explaining how voltage pulses are created
- how they are used to measure the rate of flow of oil in the pipeline
- how the voltage pulses are related to the volume of oil per second flowing in the pipeline.

In this question you will be assessed on your written communication skills including the use of specialist science terms.

Write your answer on the lined page facing.

DO NOT WRITE IN THIS SPACE



- (b) The diagram below represents the distribution network for electricity from the power station to users such as households.

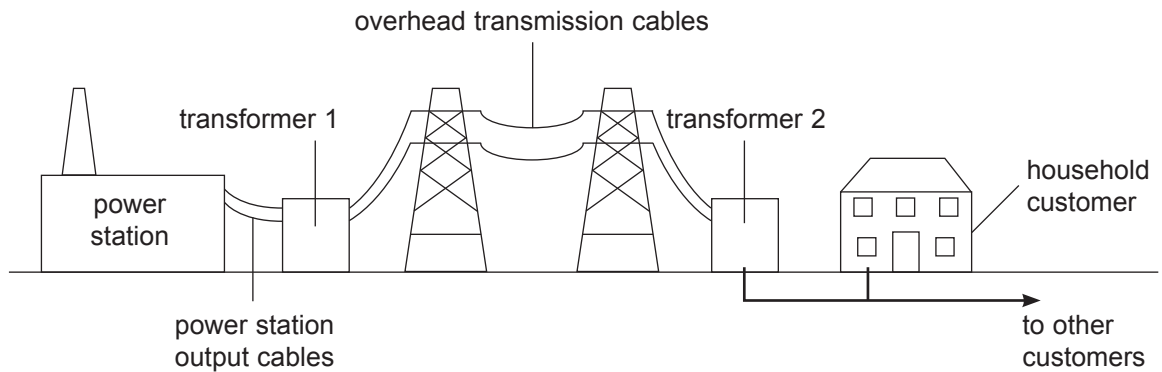

© CCEA

A power station generates electricity at a voltage of 15 kV.
This is increased to 120 kV by transformer 1.

- (i) Calculate the turns ratio $\left(\frac{N_{\text{secondary}}}{N_{\text{primary}}}\right)$ for transformer 1 used to do this.

Turns ratio = _____ [3]

- (ii) When the voltage is increased in this way is the current flowing in the transmission cables a.c. or d.c.?

_____ [1]

- (iii) Explain fully what the electricity companies do to reduce energy loss in the transmission cables.

[3]



(iv) Describe the role of transformer 2.

[2]

(c) The diagram below shows a simple electromagnet.

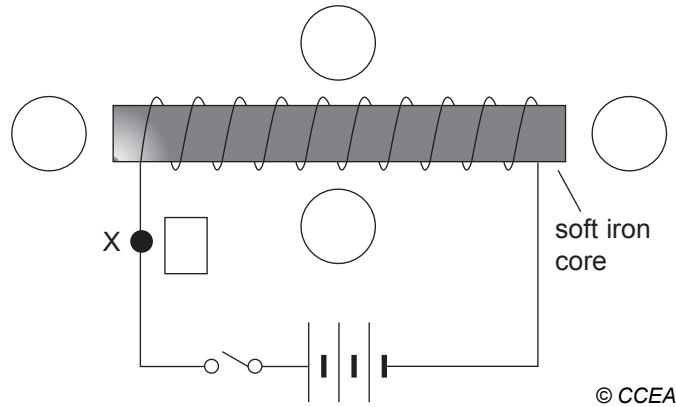

(i) The switch is closed. At the point marked X show the direction of the current flow by drawing an arrow in the box beside it. [1]

(ii) On the soft iron core mark clearly the magnetic North and South poles. [1]

(iii) The circles represent the position of a magnetic compass. Mark an arrow in each of the circles to show the direction of the magnetic field at each position. [2]

(iv) The wire used to wind the coil of the electromagnet is insulated. Explain why this must be the case.

[1]

[Turn over



5 (a) The diagram below shows our Sun and the planets that make up the Solar system.

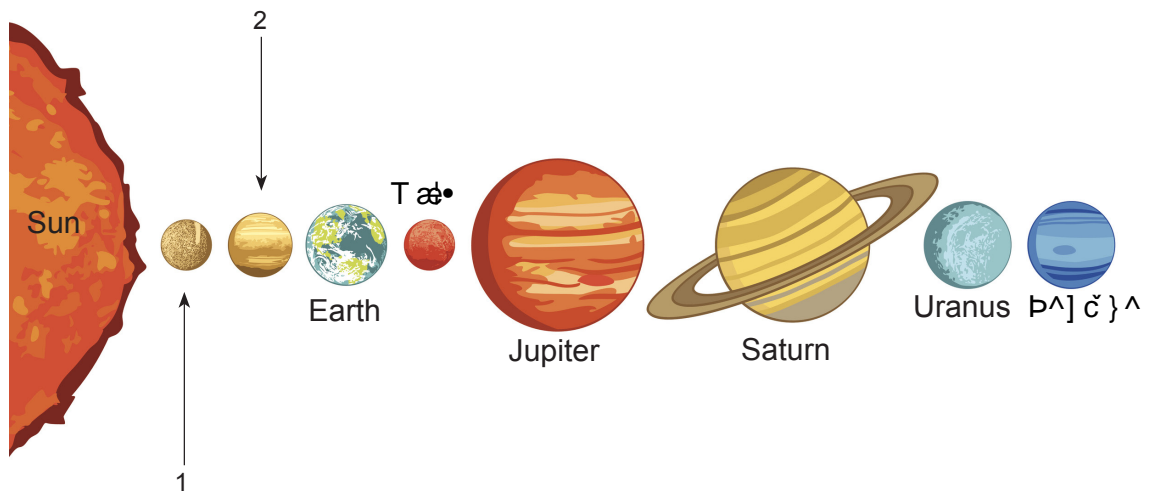

© sntpzh / iStock / Thinkstock

(i) Name the planets marked by numbers.

1 _____ 2 _____ [2]

(ii) The Solar System was probably formed from a large cloud of material known as a nebula. What two pieces of evidence support this view?

1. _____

2. _____

_____ [2]



The Sun's gravity plays a major role in our Solar System.

(iii) Describe how it affects the motion of the planets.

[2]

(iv) Describe the role gravity plays in ensuring our Sun remains stable providing energy for many millions of years.

[2]

The graph below shows how the speed of a planet in its orbit, known as its orbital speed, depends on the length of time it takes to complete one orbit, known as its orbital period.

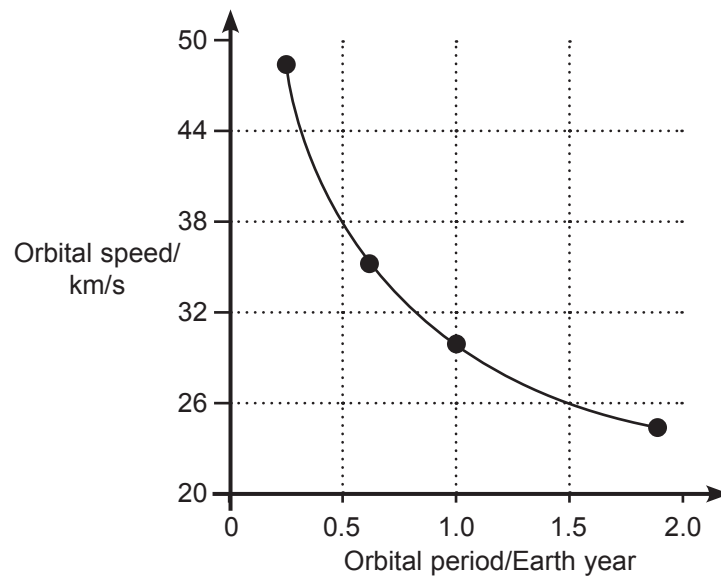

The data is for the four planets nearest the Sun.

(v) On the graph mark with an arrow the data point that represents the Earth.

[1]

[Turn over



(vi) Name the planet that has an orbital period almost twice as long as we have on the Earth.

_____ [1]

(b) Stars like our Sun produce very large amounts of energy. The diagram below illustrates the nuclear fusion process that produces this energy in many stars.

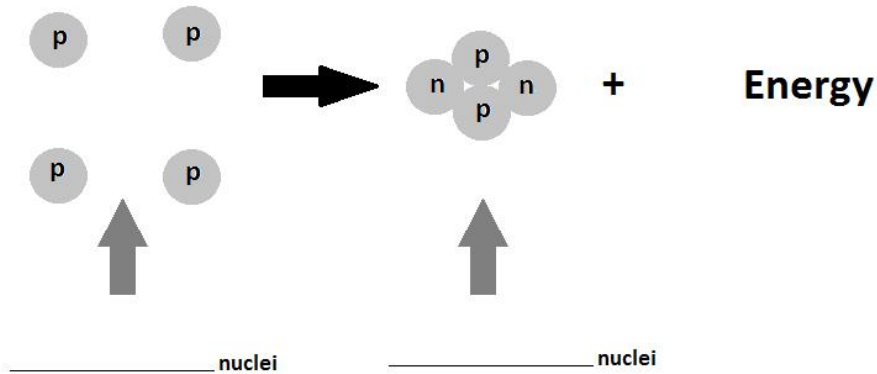

© Chief Examiner

(i) Identify the nuclei involved in this process. Write the name in the spaces provided.

[2]

(ii) How do we know that stars are mostly composed of the two gases the nuclei of which are part of the nuclear fusion reaction shown above?

_____ [1]



(c) Most scientists believe in the Big Bang model for the formation and evolution of the Universe.

The diagram below represents how the size of the Universe changed with time.

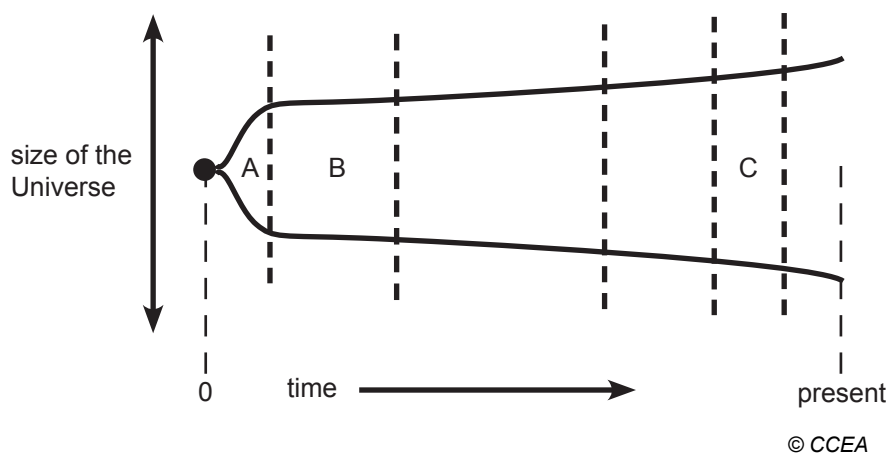

(i) During the period marked A the Universe expands rapidly. What else is happening at this period?

_____ [1]

(ii) During the period marked B two important nuclear particles were formed. Name them.

_____ and _____ [2]

(iii) During the period marked C hydrogen atoms began to form and electromagnetic radiation was able to pass through the Universe. This radiation has now been detected billions of years after it was first emitted. What name is given to the radiation?

_____ [1]

[Turn over



(iv) The diagram shows that the Universe is continuing to expand.
What observation supports this view?

[2]

(v) According to current measurements how long ago did the Big Bang occur?

[1]



6 (a) The diagram below shows a cross section through the Earth.

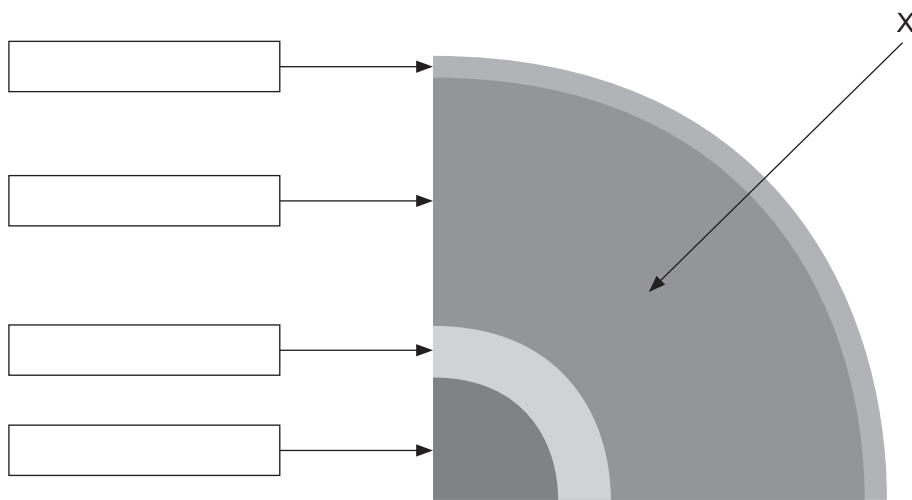

© CCEA

(i) On the diagram name the four layers into which the Earth is divided. Write your answers in the boxes provided. [4]

(ii) Explain, in detail, what the lithosphere is.

[2]

(iii) The section marked X is the widest section. Describe how the mechanical properties of its rocks change with distance from the centre of the Earth.

[2]

[Turn over



(iv) What two metals are the main constituents of the innermost layers?

_____ and _____ [2]

(v) Describe how the two innermost layers differ.

_____ [2]



(b) The rigid outermost shell of the Earth is broken up into sections as shown below. These sections are known as tectonic plates.

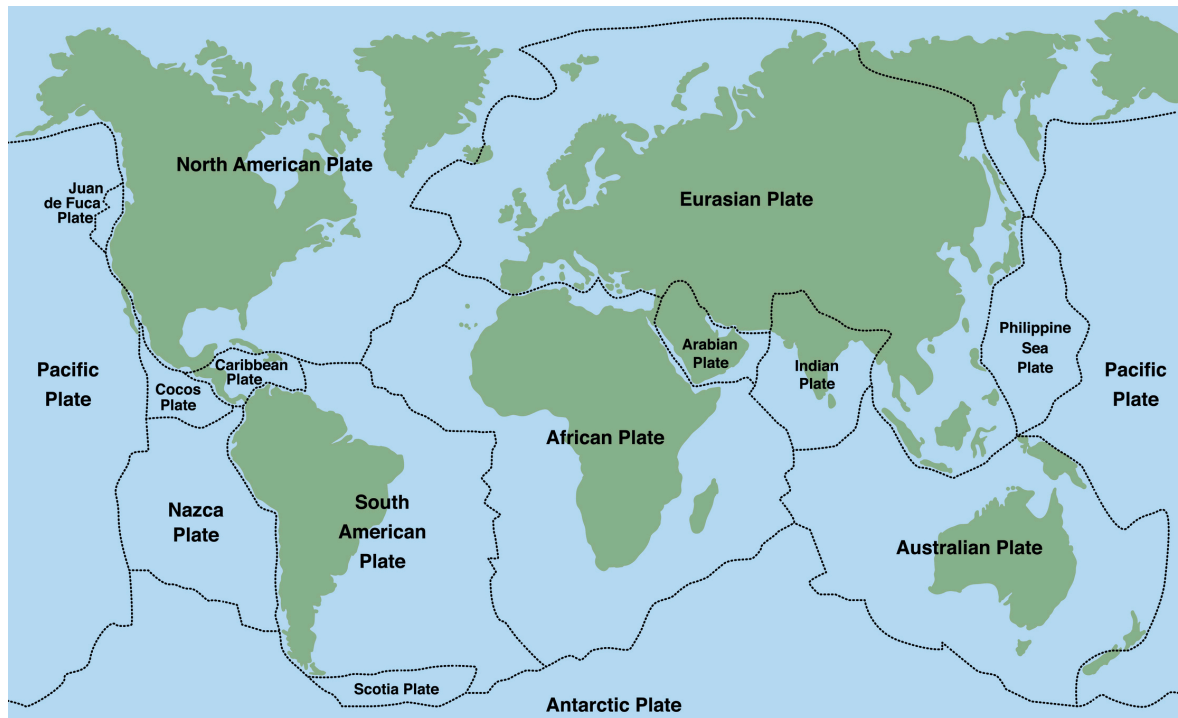

© Peter Hermes Furian / iStock / Thinkstock

Explain how earthquakes occur at some plate boundaries.

[3]

THIS IS THE END OF THE QUESTION PAPER



DO NOT WRITE ON THIS PAGE

For Examiner's use only	
Question Number	Marks
1	
2	
3	
4	
5	
6	

Total Marks	
--------------------	--

Examiner Number

Permission to reproduce all copyright material has been applied for.
In some cases, efforts to contact copyright holders may have been unsuccessful and CCEA will be happy to rectify any omissions of acknowledgement in future if notified.

203529



28GPH2228