



General Certificate of Secondary Education  
2019

Centre Number

--	--	--	--	--

Candidate Number

--	--	--	--	--

# Physics

Unit 2

Higher Tier



[GPY22]

\*GPY22\*

FRIDAY 14 JUNE, MORNING

## TIME

1 hour 30 minutes.

## INSTRUCTIONS TO CANDIDATES

Write your Centre Number and Candidate Number in the spaces provided at the top of this page.

**You must answer the questions in the spaces provided.**

**Do not write outside the boxed area on each page or on blank pages.**

Complete in black ink only. **Do not write with a gel pen.**

Answer **all** questions.

## INFORMATION FOR CANDIDATES

The total mark for this paper is 100.

Figures in brackets printed down the right-hand side of pages indicate the marks awarded to each question or part question.

Quality of written communication will be assessed in questions **2(e)** and **5(c)**.



- 1 (a) A musician plucks the strings of a guitar. The vibrations of the guitar string also produce vibrations in the air which transmit sound energy to listeners.



Source: Chief Examiner

- (i) The vibrations in a plucked guitar string are transverse waves. Describe how the particles in a transverse wave move relative to the direction of the transverse wave.

\_\_\_\_\_ [1]

- (ii) As the sound travels through the air it causes the air molecules to move. Name the type of wave of which sound is an example and describe how the air molecules move relative to the direction of the sound wave.

Type of wave \_\_\_\_\_

\_\_\_\_\_  
\_\_\_\_\_  
\_\_\_\_\_ [3]



- (b) A loudspeaker emits a sound wave of constant frequency. A microphone and a computer are used to display this sound on a screen, as shown below.

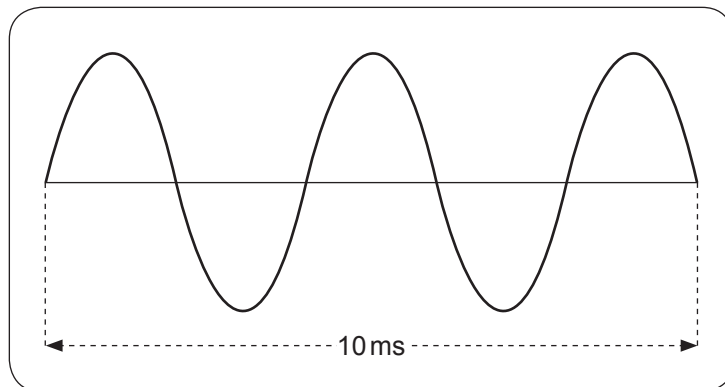

**1 ms = millisecond = 0.001 s**

- (i) How many waves occur in 10 ms?

Number of waves = \_\_\_\_\_ [1]

- (ii) Calculate the frequency of the wave.  
Include the unit for frequency with your answer.

Frequency = \_\_\_\_\_ [3]

- (iii) The speed of sound in air is 330 m/s. Calculate the wavelength of the sound.  
**Show clearly how you get your answer, starting with the equation you plan to use.**

Wavelength = \_\_\_\_\_ m [3]

**[Turn over**



- (c) A small microphone is placed on the floor of a large sports hall, as shown below. The microphone is separated from the source of sound by a large sound-absorbing wall. The source of sound makes a loud beep.

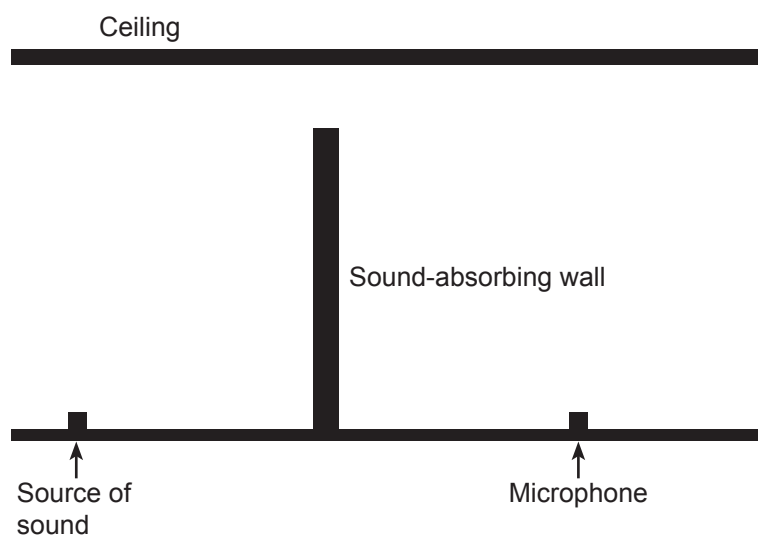

- (i) Explain how the sound reaches the microphone.

---

---

---

---

[2]



- (ii) The source of sound and two microphones **A** and **B** are placed in positions as shown in the diagram below.

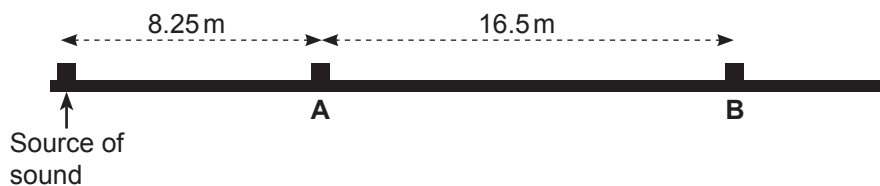

The speed of sound in air is 330 m/s.

Using this information and data taken from the diagram above calculate the time interval between the beep detected by each microphone.

**Show clearly how you get your answer, starting with the equation you plan to use.**

Time interval = \_\_\_\_\_ s [5]



(d) Electromagnetic waves have many uses.  
Answer the questions below which refer to the uses of electromagnetic waves.

(i) Which one is used to make toast? \_\_\_\_\_ [1]

(ii) Which one can produce a sun tan? \_\_\_\_\_ [1]

(iii) Which one allows us to see? \_\_\_\_\_ [1]

(iv) Which one is used in satellite communications? \_\_\_\_\_ [1]

(e) The use of electromagnetic waves to detect flying aircraft is known as  
\_\_\_\_\_ [1]

(f) Name **two** properties that are common **only** to electromagnetic waves.

1. \_\_\_\_\_

2. \_\_\_\_\_ [2]





**BLANK PAGE**

**DO NOT WRITE ON THIS PAGE**

**(Questions continue overleaf)**

11507

**[Turn over**



\*28GPY2207\*

- 2 (a) The diagram shows an object (a candle) and its virtual image as seen in a plane mirror.

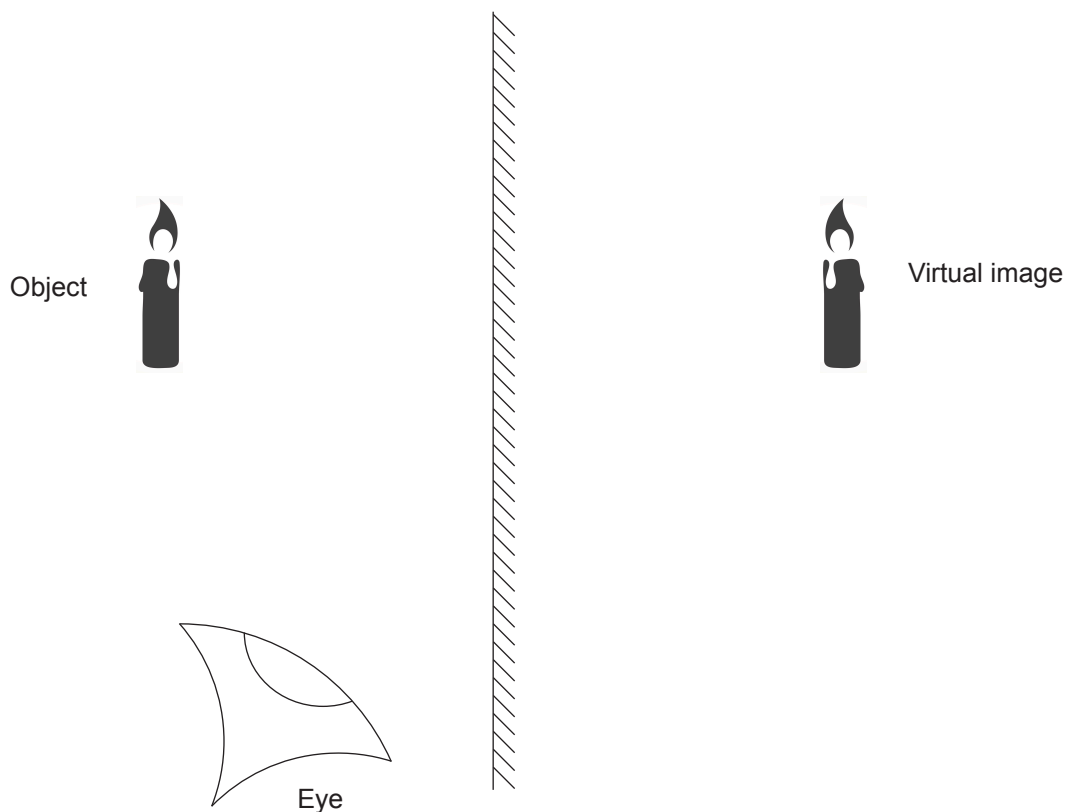

Source: Diagram by Chief Examiner / Candle © Getty Images

- (i) Draw one incident ray from the top of the candle flame and show how this ray is reflected from the mirror to reach the eye shown. [3]
- (ii) The image seen in a plane mirror is laterally inverted. What does this mean?

---

---

[1]





(b) Rainbows are caused by the refraction of sunlight by rain drops. The diagram below shows a ray of sunlight entering a raindrop and undergoing dispersion.

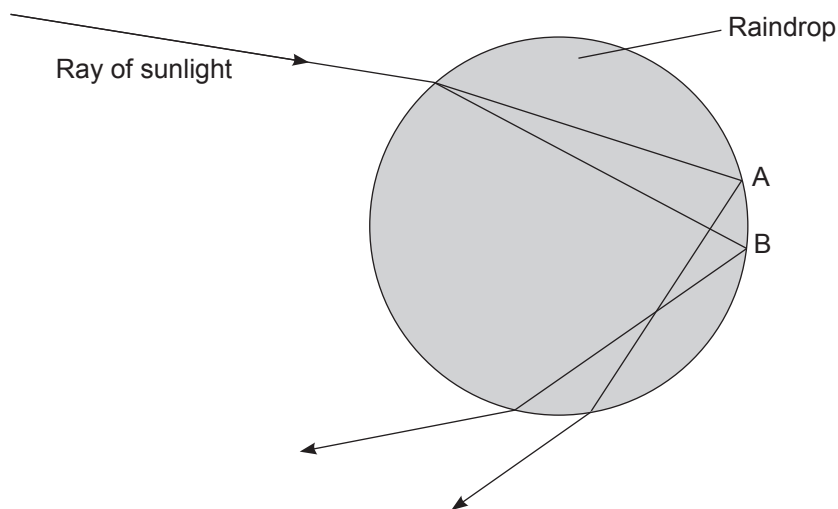

(i) Label the red ray and violet ray as they leave the raindrop. [1]

(ii) Why have you labelled the red ray and violet ray in the way you have shown?

---



---

(iii) Explain, in terms of the speed of light, your answer to part (ii).

---



---

(iv) At the points A and B the rays of light undergo total internal reflection. State the **two** conditions that must be met before a ray of light undergoes total internal reflection.

1. \_\_\_\_\_

\_\_\_\_\_

2. \_\_\_\_\_

\_\_\_\_\_

[2]  
[Turn over



(c) A converging (convex) lens is used to produce a real magnified image, as shown in the **full scale** diagram below.

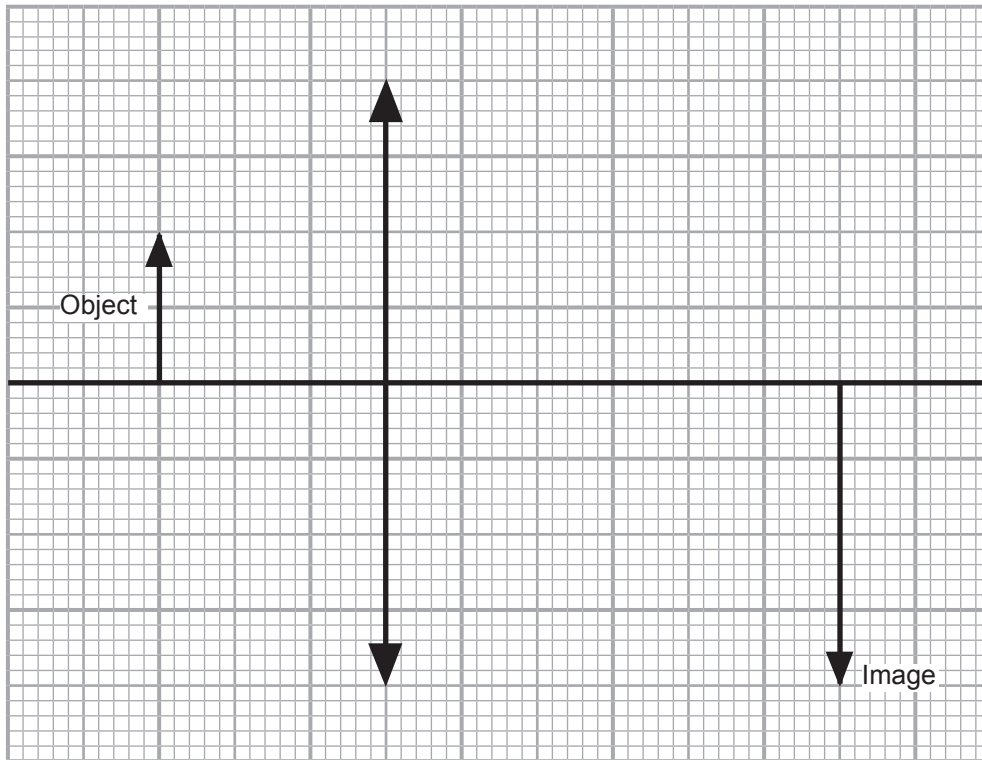

(i) Complete the diagram by drawing a ray of light that will allow you to locate the principal focus of the lens and mark the principal focus F. [3]

(ii) Measure the focal length.

Focal length = \_\_\_\_\_ cm [1]

(iii) Name an application which uses a converging (convex) lens to produce the type of image shown in the diagram.

\_\_\_\_\_ [1]



(d) A person suffers from short sight.

(i) How does this affect a person's vision?

---

---

[1]

(ii) Complete the diagram below to show how a lens corrects this problem. Write the type of lens used to correct this problem in the box. Draw the path of two rays of light from the lens to the eye and then to the retina.

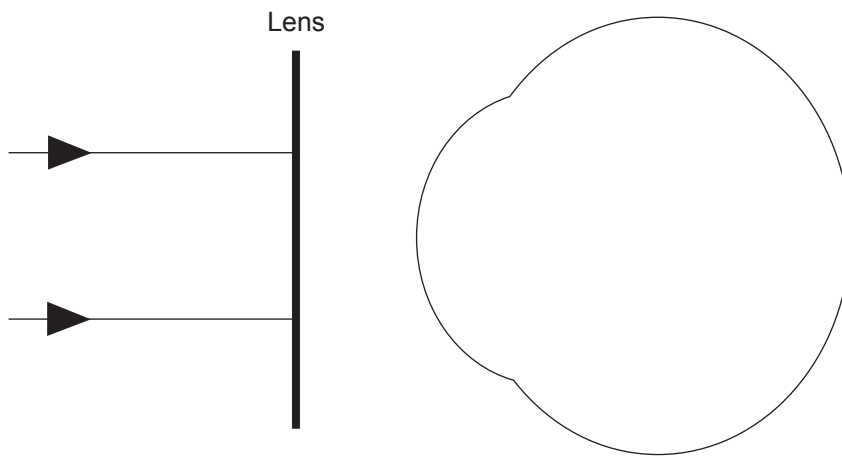

\_\_\_\_\_ lens

[4]

[Turn over



(e) When light travels from air into glass it is refracted.

Describe how you would investigate the refraction of light as it passes from air into and through a glass block.

In your description you should state the following:

- the apparatus you would use
- how the path of the refracted ray into and through the glass block is marked
- how the angles of incidence and refraction are measured
- how you would investigate, how the angle of refraction depends on the angle of incidence
- what graph you would plot to show the relationship between the angle of refraction and the angle of incidence
- what this graph would tell you

**In this question, you will be assessed on your written communication skills including the use of specialist scientific terms.**

**Write your answers on the page opposite.**





Apparatus \_\_\_\_\_

\_\_\_\_\_

Path of a ray \_\_\_\_\_

\_\_\_\_\_

\_\_\_\_\_

\_\_\_\_\_

Measurement of angles \_\_\_\_\_

\_\_\_\_\_

\_\_\_\_\_

Investigation \_\_\_\_\_

\_\_\_\_\_

\_\_\_\_\_

\_\_\_\_\_

\_\_\_\_\_

Relationship \_\_\_\_\_

\_\_\_\_\_

\_\_\_\_\_

Graph \_\_\_\_\_

\_\_\_\_\_

\_\_\_\_\_

[6]



[Turn over

11507



\*28GPY2213\*

- 3 (a) Each cell in the batteries shown below has a voltage of 1.5V.  
Complete the table by finding the voltage provided by each battery.

Battery	Voltage provided/V
	
	
	

[3]

- (b) Complete the table by finding the total resistance of each circuit.

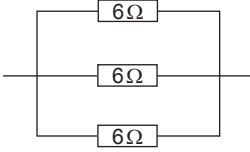
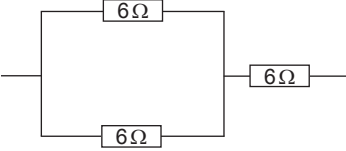
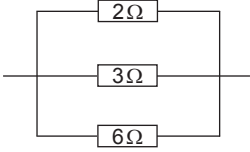
Circuit	Calculation	Total resistance/ $\Omega$
		
		
		

[4]



- (c) (i) Complete the circuit below by adding an ammeter and voltmeter so that a series of readings of voltage and current can be obtained for the filament lamp.  
Use the correct symbols for these components.

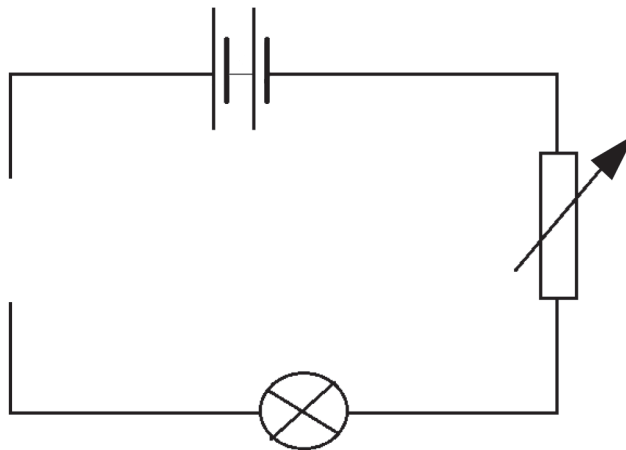

[2]

[Turn over



- (ii) Using the measurements in the table below, plot a graph of voltage on the y-axis and current on the x-axis, on the grid on the opposite page. Label each axis with the appropriate quantity and unit.

V/V	0	1	2	3	4	5	6
I/A	0	0.2	0.32	0.4	0.45	0.51	0.55

[5]

- (iii) Draw the curve of best fit through the points.

[1]

- (iv) Calculate the resistance of the filament lamp when the current is 0.25A. Use the space below for your calculation.

Resistance = \_\_\_\_\_  $\Omega$  [3]





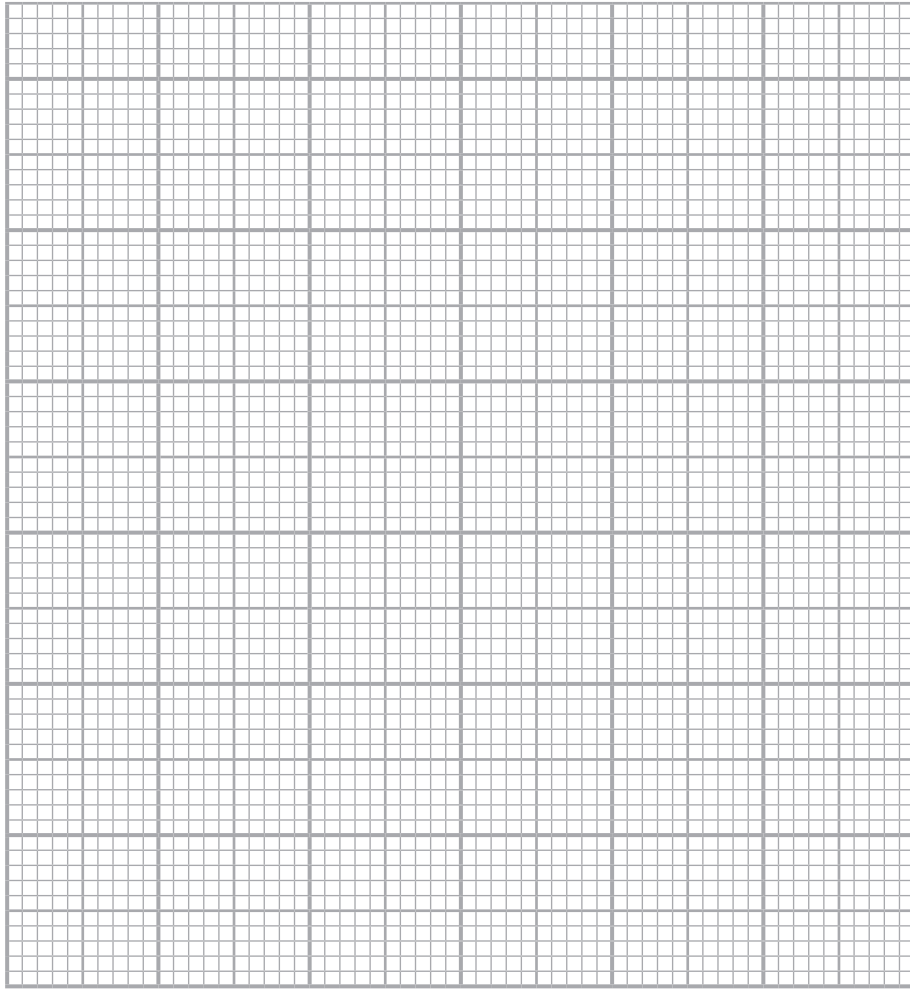

11507

[Turn over



\*28GPY2217\*

- (d) The brake lamps in a car require 12V to be lit to normal brightness. Two circuits for the brake lamps are shown below.

**Circuit 1**

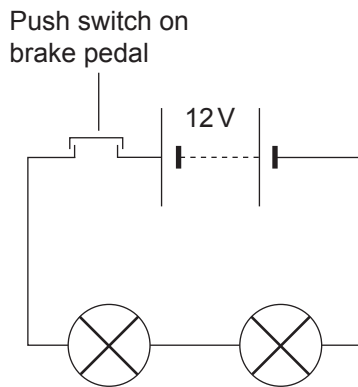

**Circuit 2**

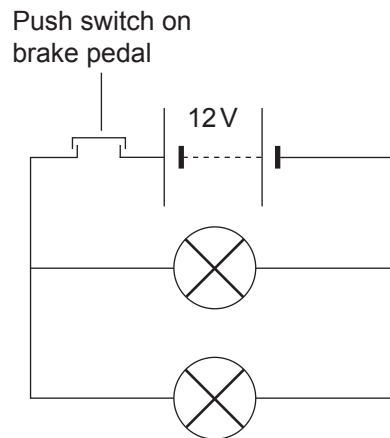

- (i) Which circuit would ensure that the brake lamps are lit to normal brightness?  
Explain your answer.

---

---

---

[2]



- (ii) The brake lamps are labelled 12 V, 24 W.  
Calculate the resistance of **one** of the brake lamps when it is operating at normal brightness.  
**Show clearly how you get your answer, starting with the equation you plan to use.**

Resistance = \_\_\_\_\_  $\Omega$  [3]



- 4 (a) The diagram shows how very large currents can be produced with simple apparatus. Here the large current is used to heat a nail.

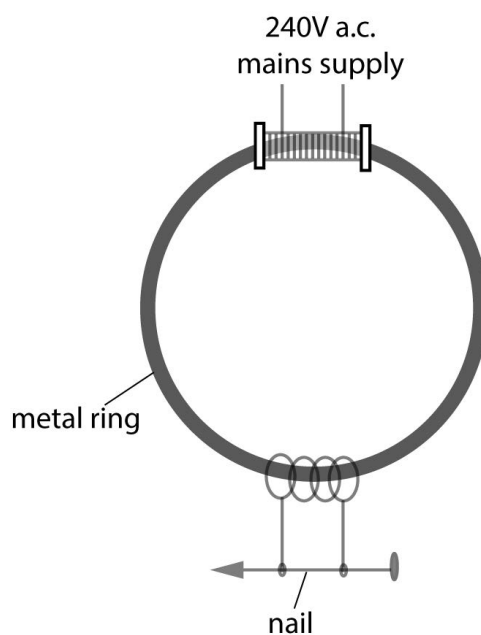

Source: Chief Examiner

- (i) What name is given to the effect which causes a voltage to be produced in one coil because of a changing current in a neighbouring coil?

\_\_\_\_\_ [1]

The two coils and the metal ring behave as a transformer.

- (ii) From what material should the metal ring be made?

\_\_\_\_\_ [1]



There are 750 turns in the upper coil and 5 turns in the coil attached to the nail.  
The voltage across the upper coil is 240 V.

- (iii) Calculate the voltage across the nail.  
**Show clearly how you get your answer, starting with the equation you plan to use.**

Voltage across nail = \_\_\_\_\_ V [3]

- (iv) The transformer has an efficiency of 1.0 (100%).  
Explain carefully what this means.

\_\_\_\_\_  
\_\_\_\_\_ [1]



(b) The diagram below shows the main features of an electricity transmission system.

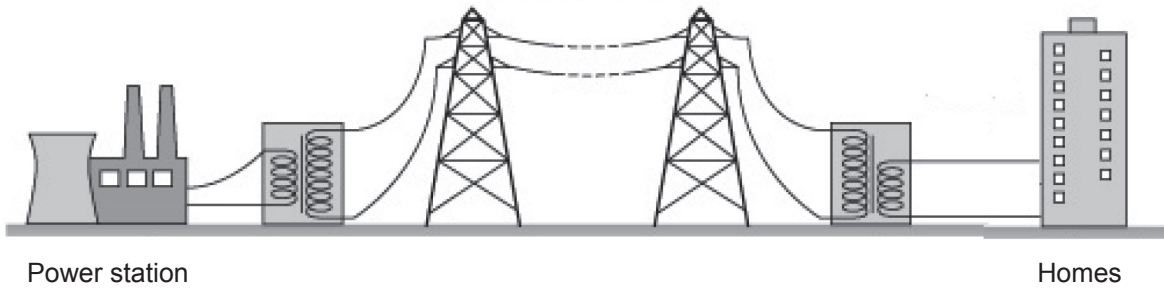

Source: Chief Examiner

(i) Describe the role transformers play in electricity transmission, giving reasons for their use.

At the power station \_\_\_\_\_  
\_\_\_\_\_  
\_\_\_\_\_

At homes \_\_\_\_\_  
\_\_\_\_\_  
\_\_\_\_\_ [4]

(ii) At the power station electricity is produced using an a.c. generator. In its simplest form what does an a.c. generator consist of?

\_\_\_\_\_  
\_\_\_\_\_ [2]





**BLANK PAGE**

**DO NOT WRITE ON THIS PAGE**

**(Questions continue overleaf)**

11507

**[Turn over**



\*28GPY2223\*

- 5 (a) Planets outside our solar system are known as exoplanets. To date, several thousand such planets have been found. Astronomers cannot see such planets, but their existence is observed as they pass in front of the star they orbit.

The diagram below shows a planet passing in front of a star.

- (i) Complete the graph to show how the brightness of the star changes as the planet passes in front of it.

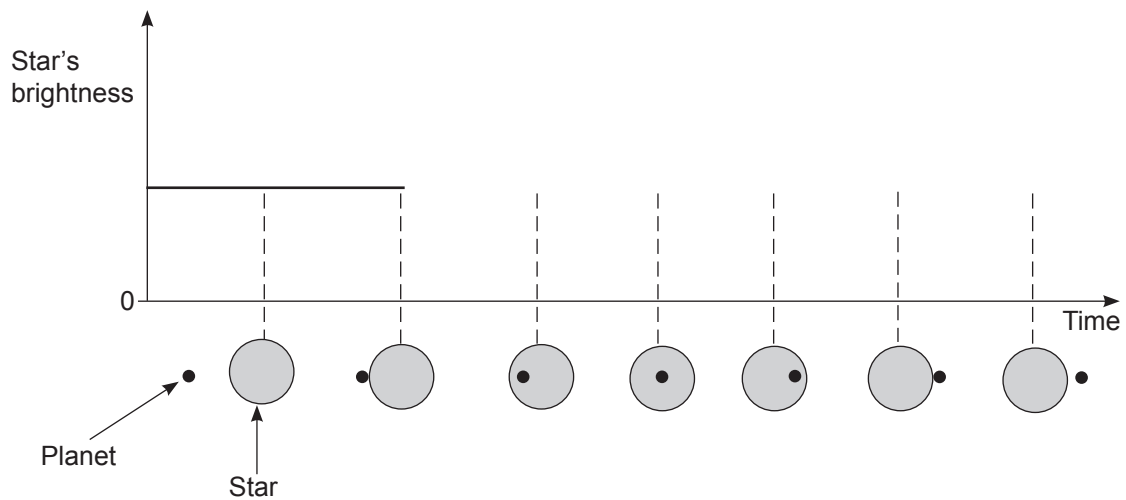

[2]

The search for life on such planets is an important part of investigating these planets.

- (ii) What gas in a planet's atmosphere is important in this search?

\_\_\_\_\_ [1]

- (iii) How do astronomers investigate the composition of a planet's atmosphere?

\_\_\_\_\_  
 \_\_\_\_\_  
 \_\_\_\_\_ [2]





(iv) State **one** limitation of travelling to one of the exoplanets, that our present technology in space travel presents.

---

---

---

[1]

(b) (i) What does CMBR stand for?

---

[1]

(ii) What model for the formation of the Universe explains CMBR?

---

[1]

(iii) Evidence for space expanding comes from CMBR and one other piece of evidence.  
Name the other piece of evidence.

---

---

[1]

[Turn over



(c) The life cycle of a star depends on its mass.  
Describe the life cycle of a star that becomes a supernova.  
In your description you should state the following:

- how the mass of such stars compares with the mass of our sun;
- what type of star they become after the main sequence period;
- what happens during a supernova and how it is detected on the earth;
- what happens after the supernova including the final state of the star.

**In this question, you will be assessed on your written communication skills including the use of specialist scientific terms.**

Mass \_\_\_\_\_  
\_\_\_\_\_

Type of star \_\_\_\_\_  
\_\_\_\_\_

What happens during the supernova and how it is detected \_\_\_\_\_  
\_\_\_\_\_  
\_\_\_\_\_  
\_\_\_\_\_

What happens after the supernova \_\_\_\_\_  
\_\_\_\_\_  
\_\_\_\_\_  
\_\_\_\_\_

[6]





---

**THIS IS THE END OF THE QUESTION PAPER**

---

**BLANK PAGE**

**DO NOT WRITE ON THIS PAGE**

11507



\*28GPY2227\*

**DO NOT WRITE ON THIS PAGE**

<b>For Examiner's use only</b>	
<b>Question Number</b>	<b>Marks</b>
1	
2	
3	
4	
5	

<b>Total Marks</b>	
--------------------	--

**Examiner Number**

Permission to reproduce all copyright material has been applied for.  
In some cases, efforts to contact copyright holders may have been unsuccessful and CCEA will be happy to rectify any omissions of acknowledgement in future if notified.

241752



\*28GPY2228\*