



National
Qualifications
2022

X857/76/12

**Physics
Paper 1 — Multiple choice**

FRIDAY, 13 MAY

9:00 AM – 9:45 AM

Total marks — 25

Attempt ALL questions.

You may use a calculator.

Instructions for the completion of Paper 1 are given on *page 02* of your answer booklet X857/76/02.

Record your answers on the answer grid on *page 03* of your answer booklet.

Reference may be made to the data sheet on *page 02* of this question paper and to the relationships sheet X857/76/22.

Space for rough work is provided at the end of this booklet.

Before leaving the examination room you must give your answer booklet to the Invigilator; if you do not, you may lose all the marks for this paper.



* X 8 5 7 7 6 1 2 *

DATA SHEET

COMMON PHYSICAL QUANTITIES

Quantity	Symbol	Value	Quantity	Symbol	Value
Speed of light in vacuum	c	$3.00 \times 10^8 \text{ m s}^{-1}$	Planck's constant	h	$6.63 \times 10^{-34} \text{ J s}$
Magnitude of the charge on an electron	e	$1.60 \times 10^{-19} \text{ C}$	Mass of electron	m_e	$9.11 \times 10^{-31} \text{ kg}$
Universal Constant of Gravitation	G	$6.67 \times 10^{-11} \text{ m}^3 \text{ kg}^{-1} \text{ s}^{-2}$	Mass of neutron	m_n	$1.675 \times 10^{-27} \text{ kg}$
Gravitational acceleration on Earth	g	9.8 m s^{-2}	Mass of proton	m_p	$1.673 \times 10^{-27} \text{ kg}$
Hubble's constant	H_0	$2.3 \times 10^{-18} \text{ s}^{-1}$			

REFRACTIVE INDICES

The refractive indices refer to sodium light of wavelength 589 nm and to substances at a temperature of 273 K.

Substance	Refractive index	Substance	Refractive index
Diamond	2.42	Water	1.33
Crown glass	1.50	Air	1.00

SPECTRAL LINES

Element	Wavelength (nm)	Colour	Element	Wavelength (nm)	Colour
Hydrogen	656	Red	Cadmium	644	Red
	486	Blue-green		509	Green
	434	Blue-violet		480	Blue
	410	Violet	Lasers		
	397	Ultraviolet	Element	Wavelength (nm)	Colour
	389	Ultraviolet	Carbon dioxide	9550 } 10 590 }	Infrared
Sodium	589	Yellow	Helium-neon	633	Red

PROPERTIES OF SELECTED MATERIALS

Substance	Density (kg m^{-3})	Melting point (K)	Boiling point (K)
Aluminium	2.70×10^3	933	2623
Copper	8.96×10^3	1357	2853
Ice	9.20×10^2	273
Sea Water	1.02×10^3	264	377
Water	1.00×10^3	273	373
Air	1.29
Hydrogen	9.0×10^{-2}	14	20

The gas densities refer to a temperature of 273 K and a pressure of $1.01 \times 10^5 \text{ Pa}$.

Total marks — 25
Attempt ALL questions

1. A ball is thrown vertically upwards and falls back to its starting position.
The acceleration-time graph represents the motion of the ball.

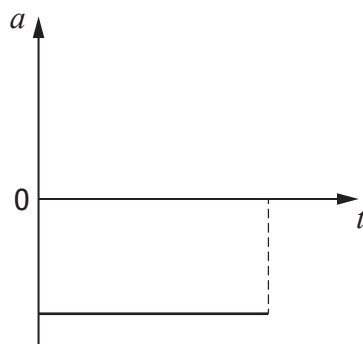

Which of the following velocity-time graphs represents the same motion?

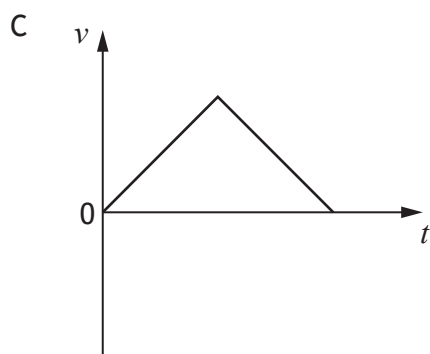
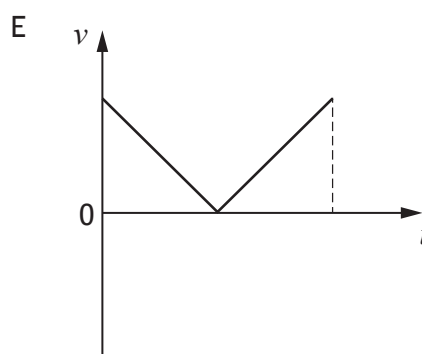
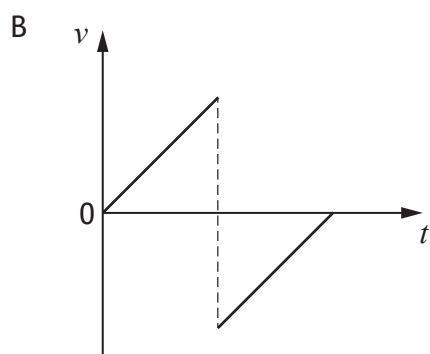
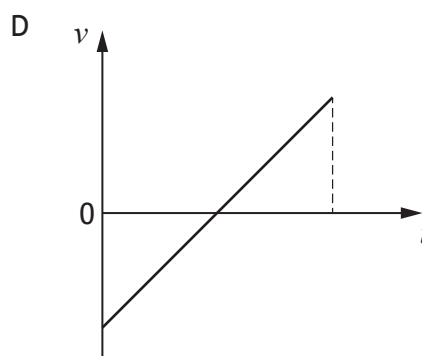
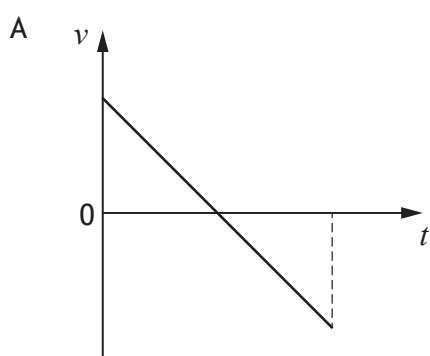

2. A student uses the apparatus shown to determine the acceleration of a trolley as it moves down a ramp.

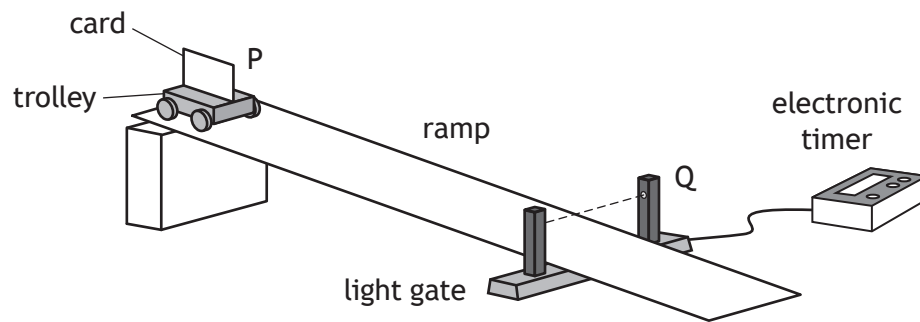

The trolley is released from rest at point P and moves down the ramp.

A card attached to the trolley passes through a light gate at point Q.

The time for the card to pass through the light gate is displayed on the electronic timer.

The vehicle's acceleration a is determined using the relationship

$$v^2 = u^2 + 2as$$

The student makes the following statements about the terms u , s , and v :

- I $u = 0 \text{ m s}^{-1}$
- II $s =$ the length of the card
- III $v = \frac{\text{distance between P and Q}}{\text{time displayed on timer}}$

Which of these statements is/are correct?

- A I only
- B II only
- C I and II only
- D I and III only
- E I, II and III

3. A spacecraft unloads cargo on the surface of the Moon.
The gravitational field strength on the Moon is 1.6 N kg^{-1} .

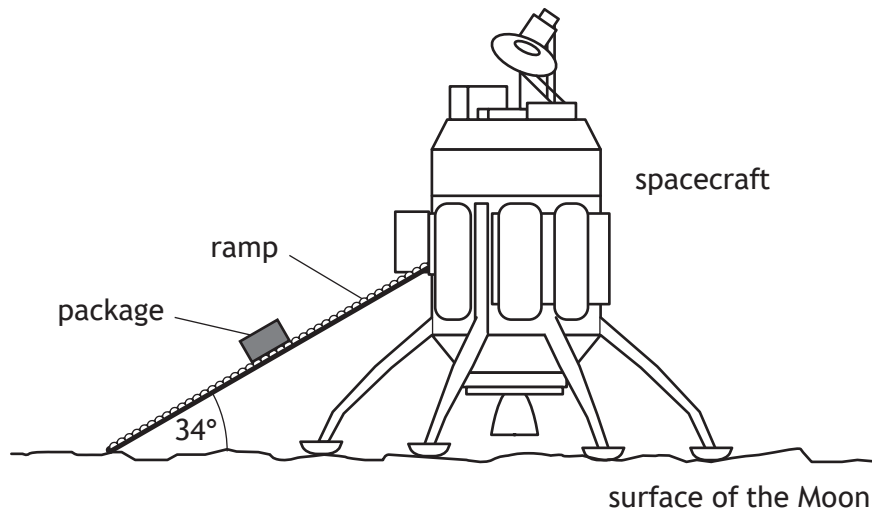

A package of mass 3.0 kg moves down the ramp.

The component of the weight of the package acting parallel to the ramp is:

- A 0.89 N
- B 2.7 N
- C 4.0 N
- D 4.8 N
- E 16 N .

[Turn over

4. Two blocks are suspended from a ceiling by ropes as shown.

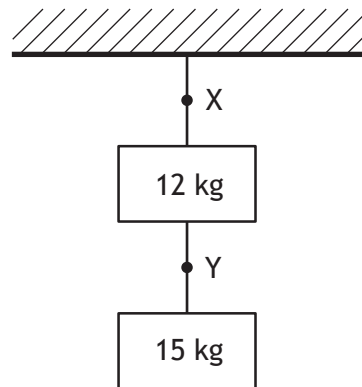

Which row in the table shows the tension in the rope at point X and the tension in the rope at point Y?

	Tension at point X (N)	Tension at point Y (N)
A	27	15
B	120	29
C	120	150
D	260	29
E	260	150

5. During an experiment a student inside a lift stands on a newton balance.

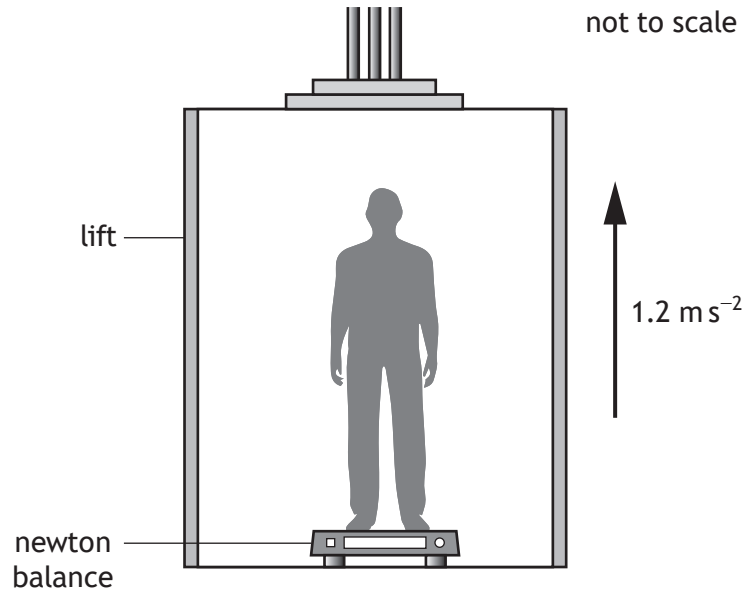

The mass of the student is 50.0 kg.

The lift accelerates upwards at 1.2 m s^{-2} .

The reading on the newton balance is:

- A 60 N
 - B 430 N
 - C 490 N
 - D 550 N
 - E 590 N.
6. Water flows at a rate of $1.0 \times 10^6 \text{ kg}$ per second over the Victoria Falls.
The Victoria Falls are 120 m high.
The total power delivered by the water in falling through 120 m is:
- A $1.2 \times 10^{12} \text{ W}$
 - B $1.2 \times 10^9 \text{ W}$
 - C $1.2 \times 10^8 \text{ W}$
 - D $8.5 \times 10^{-10} \text{ W}$
 - E $8.5 \times 10^{-11} \text{ W}$.

[Turn over

7. A spacecraft passes the Earth at a speed of $0.4c$.

A light on the spacecraft pulses on and off.

A passenger on the spacecraft measures the time between the pulses as 2.5 s.

An observer on Earth measures the time between the pulses as:

- A 2.3 s
- B 2.5 s
- C 2.7 s
- D 3.0 s
- E 3.2 s.

8. A student makes the following statements about the expanding Universe:

- I The evidence supporting the existence of dark matter comes from estimations of the mass of galaxies.
- II The evidence supporting the existence of dark energy comes from the accelerating rate of expansion of the Universe.
- III The peak wavelength of radiation emitted by hotter stars is longer than that for cooler stars.

Which of these statements is/are correct?

- A I only
- B II only
- C III only
- D I and II only
- E I, II and III

9. A police car is travelling at a constant speed of 31.0 m s^{-1} towards a stationary observer. The siren on the car emits a sound with a frequency of 820 Hz.

The speed of sound in air is 340 m s^{-1} .

The frequency of the sound heard by the observer is:

- A 745 Hz
- B 751 Hz
- C 820 Hz
- D 895 Hz
- E 902 Hz.

10. A proton enters a region of magnetic field as shown.

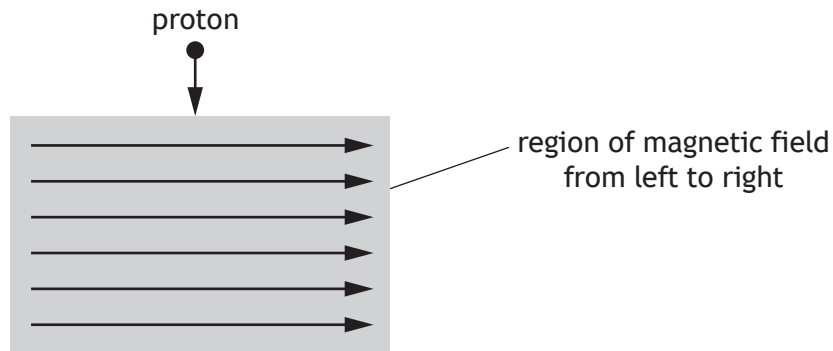

The direction of the force exerted by the magnetic field on the proton as it enters the field is:

- A out of the page
- B into the page
- C to the left
- D to the right
- E towards the bottom of the page.

11. The masses of three particles are shown.

Particle	Mass (kg)
Electron	9.11×10^{-31}
Proton	1.673×10^{-27}
Higgs boson	2.22×10^{-25}

How many orders of magnitude greater is the mass of a Higgs boson compared to the mass of a proton?

- A 7.54×10^{-3}
- B 2
- C 5
- D 133
- E 2.44×10^5

[Turn over

12. A proton consists of two up quarks and a down quark.
A student makes the following statements about protons:

- I Protons are baryons.
- II Protons are hadrons.
- III Protons are fermions.

Which of these statements is/are correct?

- A I only
 - B II only
 - C III only
 - D I and II only
 - E I, II and III
13. The following statement represents part of a radioactive decay series.

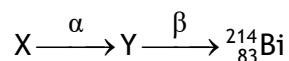

Nucleus X undergoes alpha emission to produce nucleus Y.

Nucleus Y then undergoes beta emission.

Nucleus X is:

- A ${}_{85}^{218}\text{At}$
- B ${}_{82}^{214}\text{Pb}$
- C ${}_{84}^{218}\text{Po}$
- D ${}_{86}^{218}\text{Rn}$
- E ${}_{80}^{210}\text{Hg}$.

14. The following statement represents a nuclear reaction.

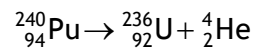

The total mass of the particles before the reaction is 398.626×10^{-27} kg.

The total mass of the particles after the reaction is 398.615×10^{-27} kg.

The energy released in this reaction is:

- A 1.1×10^{-29} J
 - B 3.3×10^{-21} J
 - C 5.0×10^{-13} J
 - D 9.9×10^{-13} J
 - E 3.6×10^{-8} J.
15. The irradiance of light incident on a surface from a point source is 20.0 W m^{-2} .
The distance between the point source and the surface is 5.0 m.
The point source is now moved to a distance of 25.0 m from the surface.
The irradiance of the light incident on the surface is now:
- A 0.032 W m^{-2}
 - B 0.80 W m^{-2}
 - C 1.2 W m^{-2}
 - D 4.0 W m^{-2}
 - E 100 W m^{-2} .

[Turn over

16. Light from a laser is incident on a grating as shown.

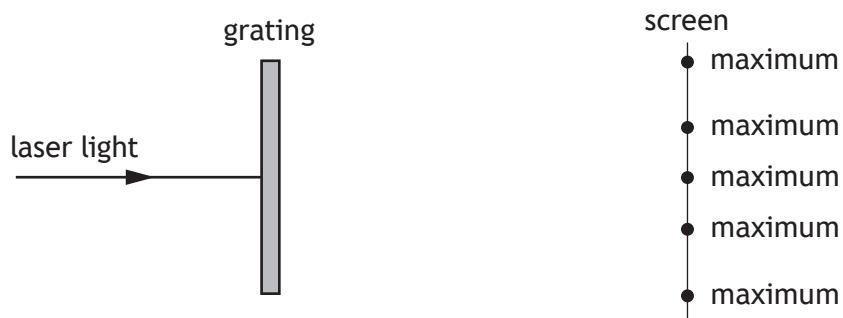

A series of interference maxima are observed on the screen.

A student makes the following statements about the interference pattern observed on the screen:

- I Increasing the distance between the grating and the screen increases the distance between the observed maxima.
- II Increasing the distance between the laser and the grating increases the distance between the observed maxima.
- III Decreasing the distance between the slits on the grating decreases the distance between the observed maxima.

Which of the statements is/are correct?

- A I only
- B II only
- C I and III only
- D II and III only
- E I, II and III

17. Which row in the table shows what happens to the speed, frequency, and wavelength of red light as it passes from diamond into air?

	Speed	Frequency	Wavelength
A	decreases	decreases	no change
B	decreases	no change	decreases
C	decreases	increases	increases
D	increases	no change	increases
E	increases	increases	increases

18. The output from a signal generator is connected to an oscilloscope. The trace seen on the oscilloscope screen is shown.

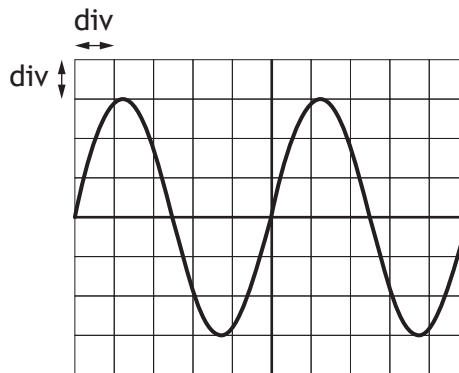

The Y-gain setting on the oscilloscope is 2.0 V/div.

The time base setting on the oscilloscope is 5 ms/div.

Which row in the table gives the rms voltage and the frequency of the output from the signal generator?

	rms voltage (V)	Frequency (Hz)
A	4.2	25
B	4.2	40
C	6.0	40
D	6.0	200
E	8.5	25

[Turn over

19. Three resistors are connected to a 3.0 V power supply as shown.

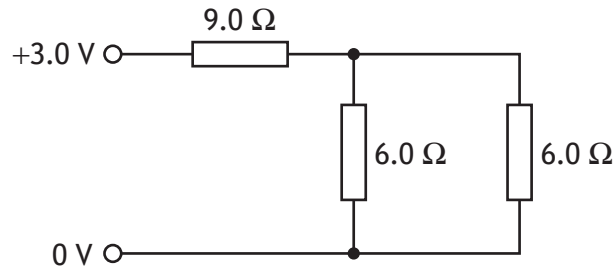

The power supply has negligible internal resistance.

The power dissipated in the circuit is:

- A 0.25 W
- B 0.43 W
- C 0.75 W
- D 2.1 W
- E 4.0 W.

20. Six resistors, each of resistance 5 Ω, are connected to a 12 V power supply as shown.

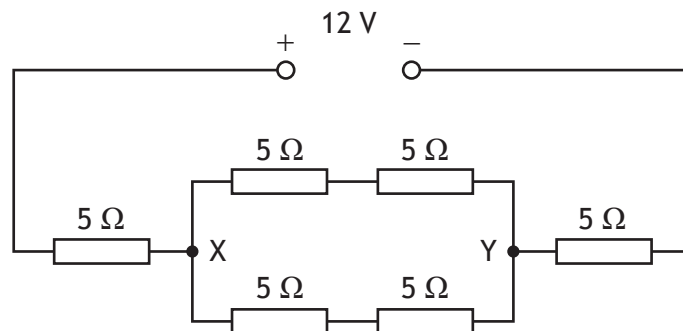

The power supply has negligible internal resistance.

Which row in the table shows the total circuit resistance and the potential difference across X and Y?

	Total circuit resistance (Ω)	Potential difference across X and Y (V)
A	15	2
B	15	4
C	20	6
D	30	8
E	30	12

21. A circuit is set up as shown.

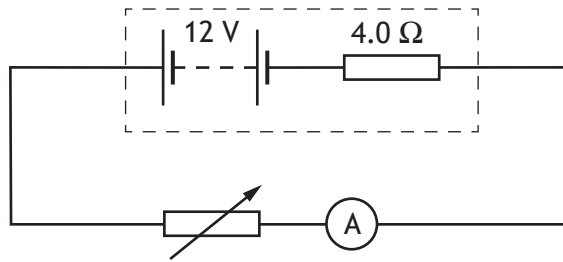

The resistance of the variable resistor is set to 6.0Ω .

The lost volts due to the internal resistance of the battery is:

- A 1.2 V
- B 4.8 V
- C 6.0 V
- D 7.2 V
- E 8.0 V.

22. A circuit is set up as shown.

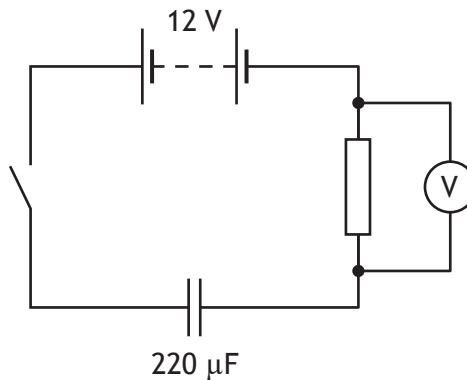

The battery has negligible internal resistance.

The capacitor is initially uncharged.

The switch is now closed.

When the reading on the voltmeter is 7.0 V, the charge stored on the capacitor is:

- A $3.1 \times 10^{-5} \text{ C}$
- B $4.4 \times 10^{-5} \text{ C}$
- C $1.1 \times 10^{-3} \text{ C}$
- D $1.5 \times 10^{-3} \text{ C}$
- E $2.6 \times 10^{-3} \text{ C}.$

23. A circuit is set up as shown.

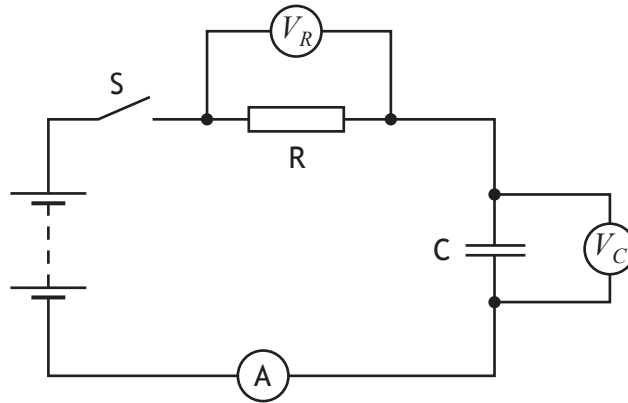

The capacitor is initially uncharged. Switch S is closed.

Which graphs show how the potential difference V_R across resistor R, the potential difference V_C across capacitor C, and the current I in the circuit, vary with time t as the capacitor charges?

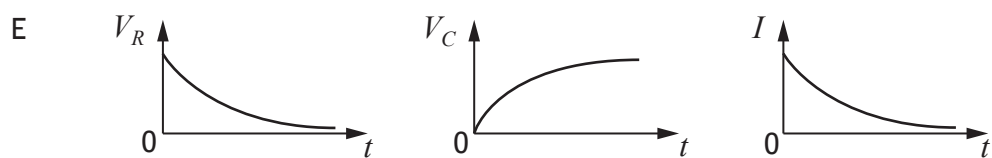
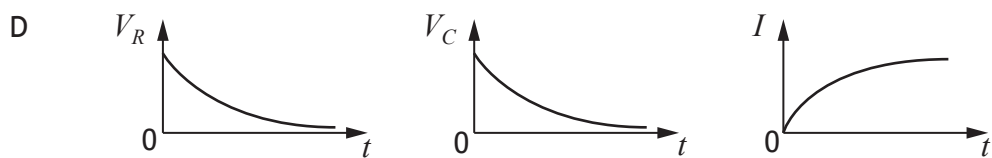
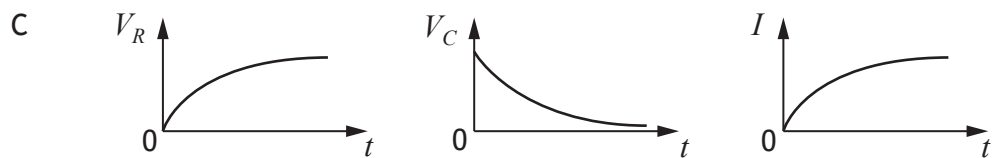
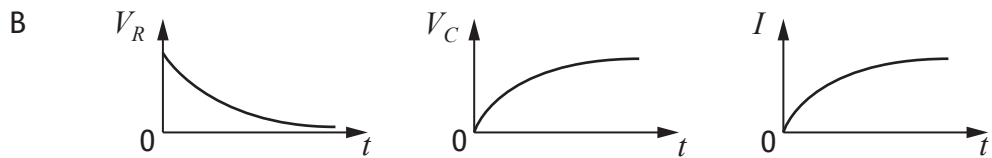
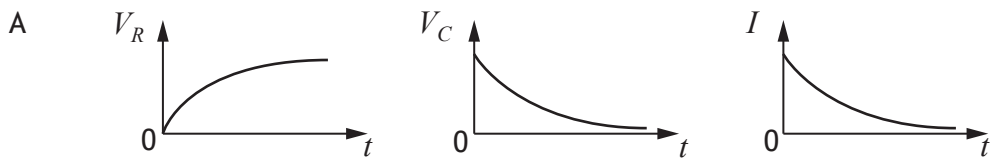

24. Which row in the table describes the conduction band and the gap between the conduction band and the valence band in an insulator?

	Conduction band	Gap between conduction band and valence band
A	unfilled	bands overlap
B	full	bands overlap
C	unfilled	large gap
D	full	small gap
E	full	large gap

25. Astronomers use the following relationship to estimate the mass M of a galaxy

$$M = \frac{v^2 r}{G}$$

where v is the orbital speed of a star in the outer regions of the galaxy, in m s^{-1}

r is the orbital radius of the star, in m

G is the Universal Constant of Gravitation.

A star orbits at a radius of 4.0×10^{20} m in the outer regions of the Triangulum galaxy.

The orbital speed of the star is 120 km s^{-1} .

Based on this information, the mass of the Triangulum galaxy is:

- A 3.8×10^{20} kg
- B 7.2×10^{32} kg
- C 8.6×10^{34} kg
- D 7.2×10^{35} kg
- E 8.6×10^{40} kg.

[END OF QUESTION PAPER]

SPACE FOR ROUGH WORK

SPACE FOR ROUGH WORK

[BLANK PAGE]

DO NOT WRITE ON THIS PAGE